

Demension

Brushless

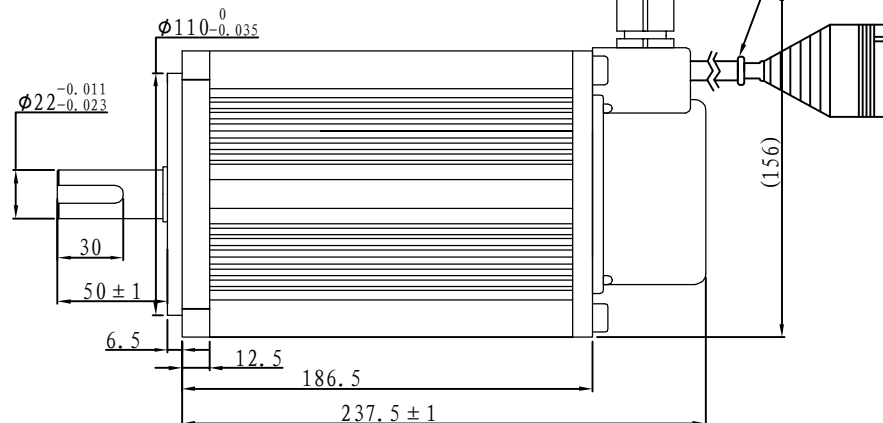

Motor power line: a length of 500 mm
 Plug-in models: SP75-8#
 Hall signal lines: a length of 500 mm
 Plug-in type: DJ7061-1.5

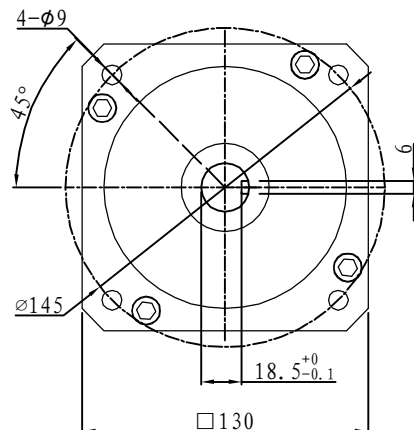
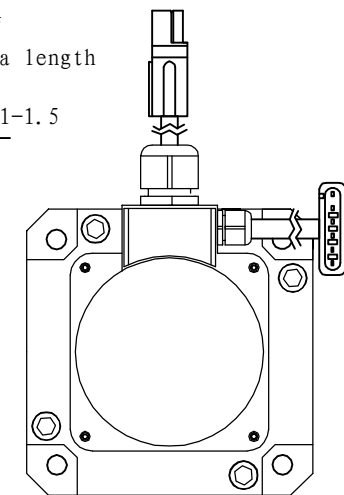

Motor to Hall Relationship

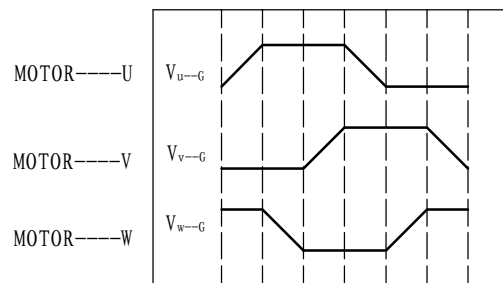
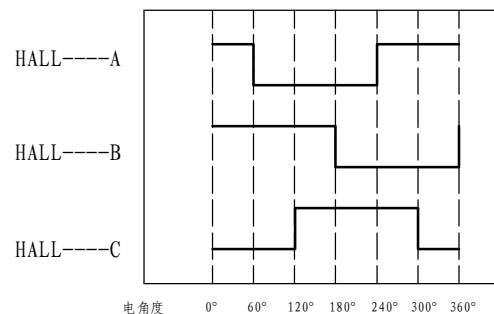

PHASE TO GROUND VOLTAGE
 ROTATION CW FROM THE FLANGE

Line Define

Power Wire

Red	Motor U
Yellow	Motor V
Blue	Motor W

Feedback Wire

Hall line colour	Hall signal definition	Plug serial number
Orange and black	5V	1
Orange	0V	2
Yellow	Hall A	4
Blue	Hall B	5
Green	Hall C	6

Tecnichal Data

Type	130WD-M1 0020-96V
Power (KW)	2.1
Rated voltage (V)	96
Rated current (A)	25.7
Rated speed (rpm)	2000
Rated torque (NM)	10
Rotor inertia (Kgcm ²)	21.4
Protection rank	IP65
Insulation rank	F
Appropriate environment	Temperature: 0~50°C Humidity: <90% (No dewdrop)
Motor weight (KG)	12