

BLD-120A BLDC Motor driver

Product features

- Drive motor under 120W
- Acceleration and deceleration settings
- Power protection function (max current setting)
- Easy operation with external potentiometer
- Speed setting via external analog and PWM
- Compact size

Electrical Specification

Parameters	Min Value	Typical Value	Max Value	Unit
Power supply	12	24	30	VDC
Output current	-	-	8	A
Over voltage protection	-	-	5	V
Under voltage protection	-	20	-	mA
External potentiometer	-	10k	-	Ω
Input analog voltage	-	-	5	VDC
Speed control range	-	-	20000	RPM

* Limited by the maximum rated speed of the motor

Functions setting

Max output current setting

P-sv current setting is for protecting the driver when it runs under over-load condition via over-current alarm. The set current value should be matched with the rated current of the matched motor and real voltage used. The set range: 1.6A-8A.

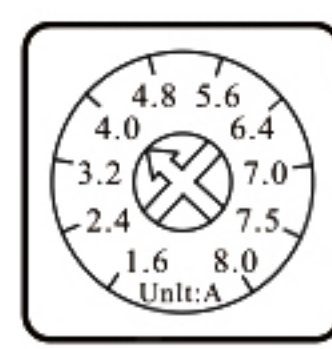

P-sv Current

Acceleration and deceleration settings

This potentiometer can be used for adjusting acceleration and deceleration time directly. Acceleration is the time the motor needs from stationary state to rated speed state; Deceleration time is the time the motor needs from rated speed state to stationary state. The range can be set: 0.3s-15s.

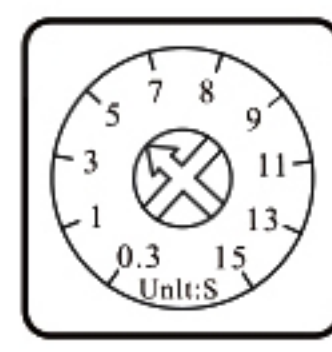

ACC/DEC

Machine dimension

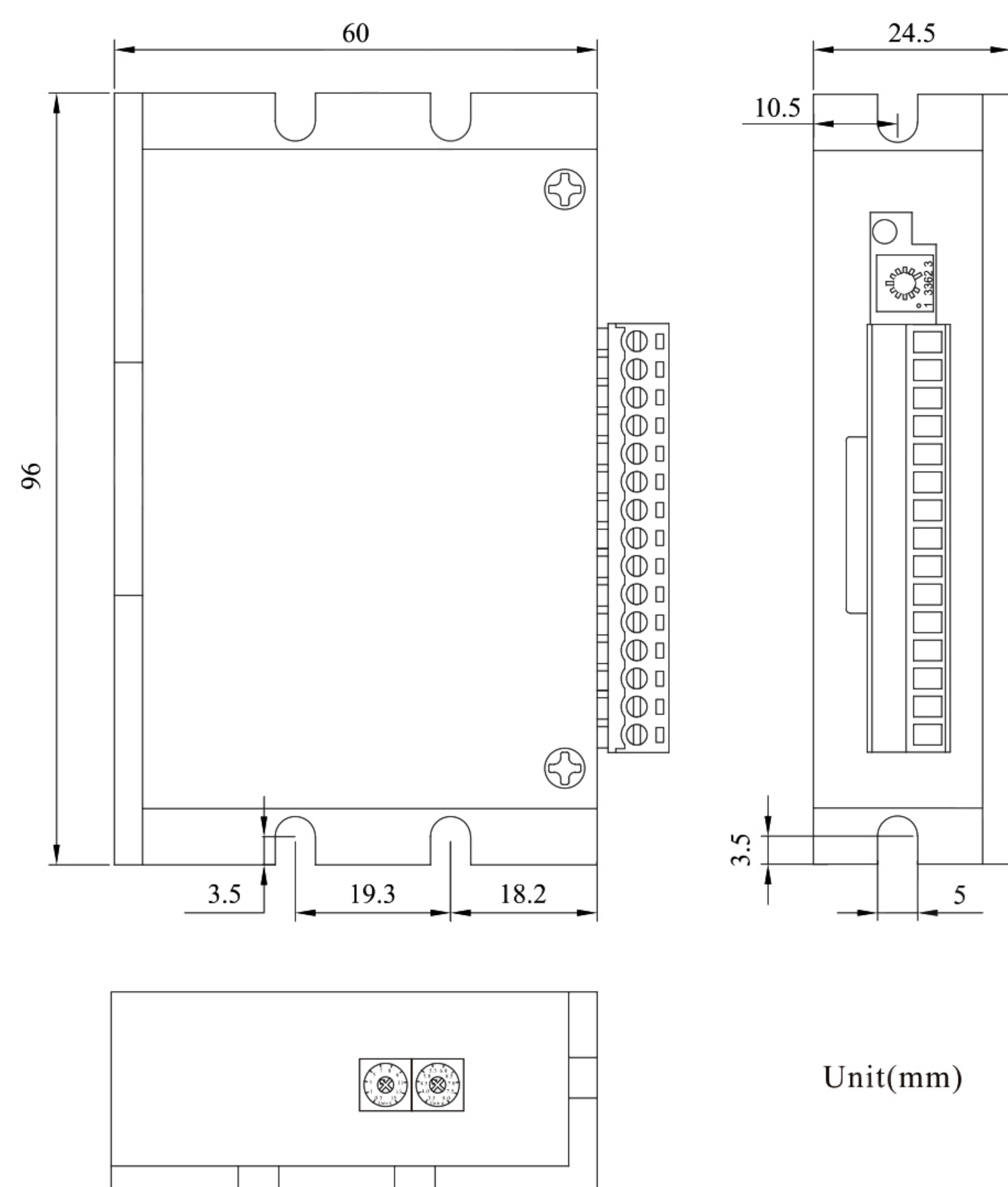

Unit(mm)

Port signal description

CN Terminal	Signal category	Functional Description
BRK	Control signal	Motor brake stop control signal; when BRK and COM connects, motor brake stops.
EN		Motor stop signal port; When EN and COM disconnect, motor stops slowly while when they are connected, motor runs.
F/R		Motor direction control terminal; F/R and COM disconnect, motor will rotate clockwise; otherwise, motor will rotate anticlockwise.
COM		Common port(0V)
SV		External speed settingsignal input terminal; when connecting external potentiometer, the middle terminal connects SV, the other two terminals connect to REF and COM.
REF+	Hall signal	BLDC Hall signal power positive pole
HU		Hall sensor signal Hu
HV		Hall sensor signal Hv
HW		Hall sensor signal Hw
REF-		BLDC Hall signal power negative electrode
W	Motor connection	Motor line W phase
V		Motor line V phase
U		Motor line U phase
DC+	Power connection	Power supply positive electrode (12-30VDC)
DC-		Power supply negative electrode (Hall sensor negative electrode)

Driver interface and wiring diagram

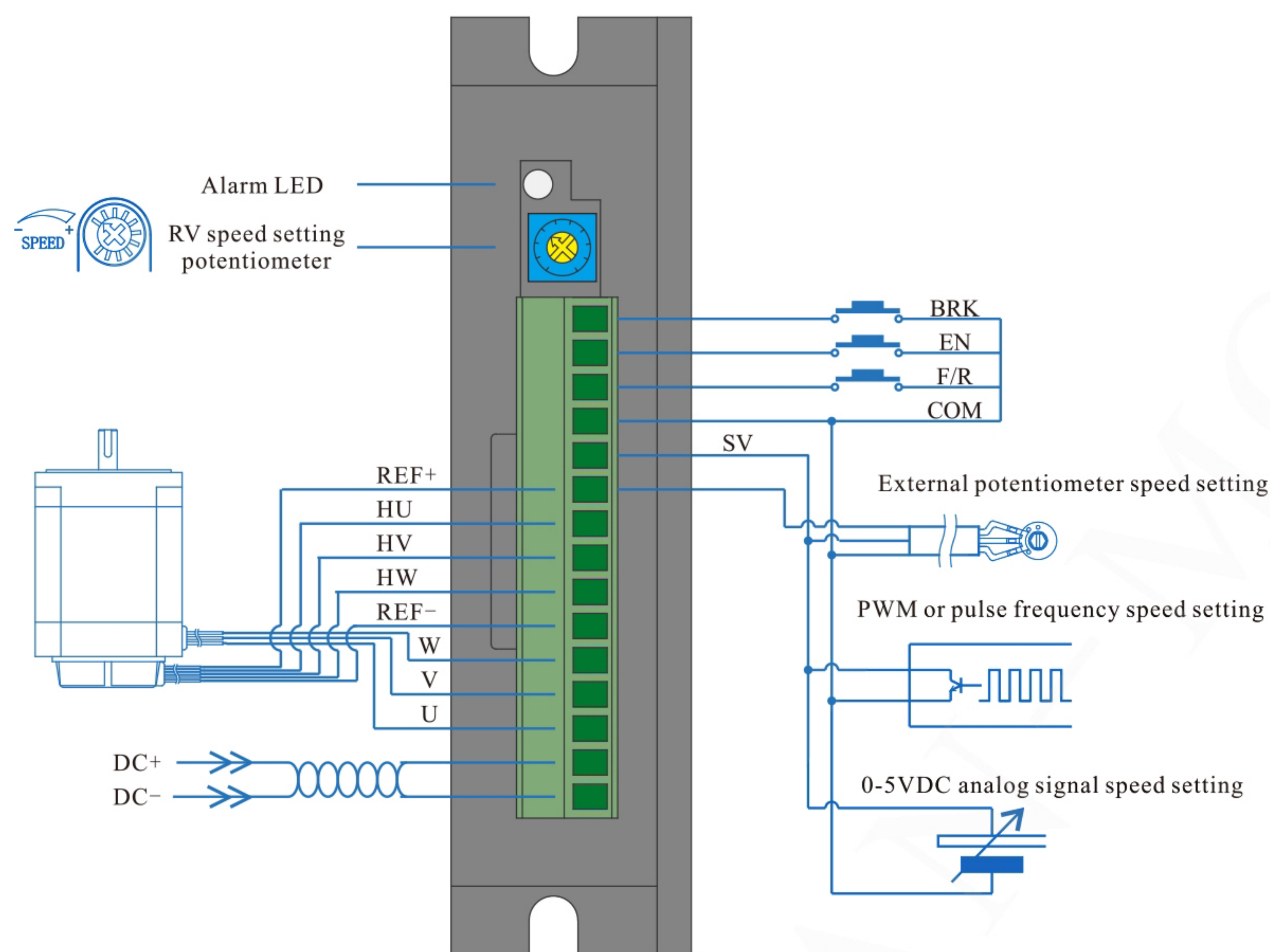

Speed setting via built-in potentiometer

Motor speed increases when RV knobs is rotated clockwise, when anticlockwise, motor speed decreases. If customers use others speed setting modes, RV should be rotated anticlockwise to limit position.

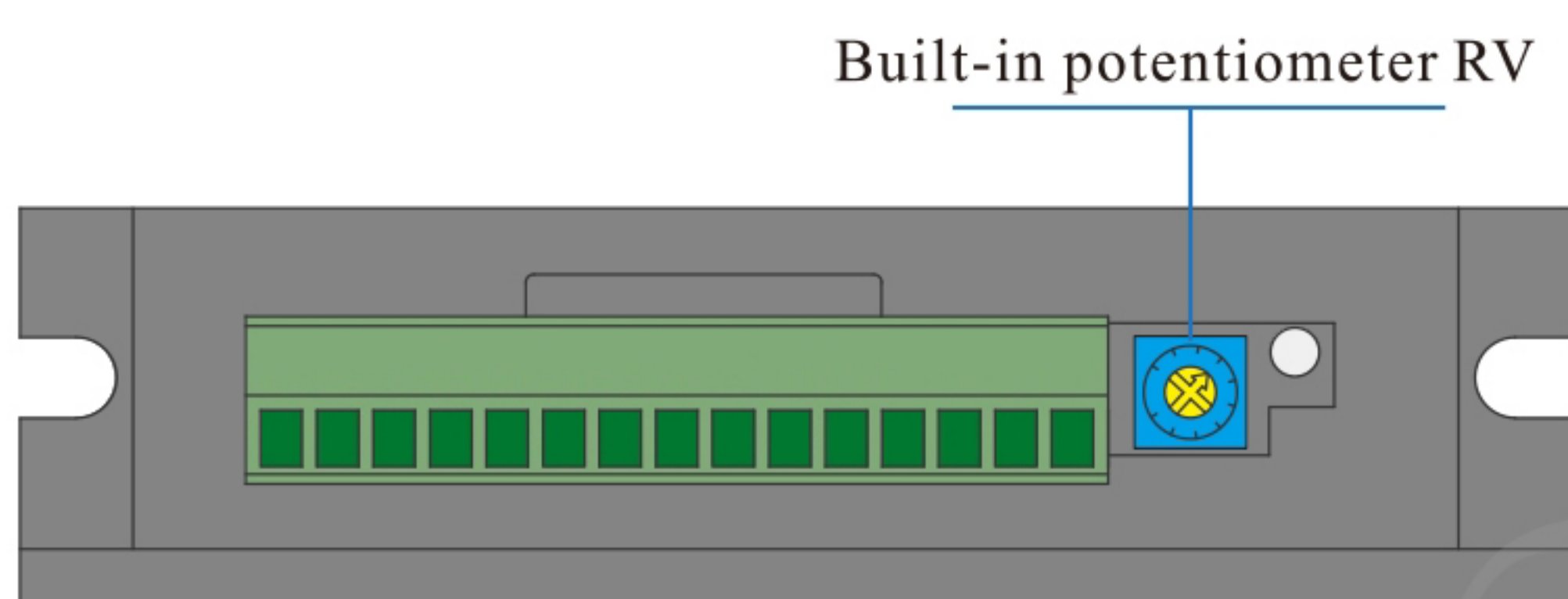

Speed setting via external potentiometer

Use a suitable potentiometer with a resistance value of 10KΩ; when connect external potentiometer, the middle terminal connects to SV. the other two terminals connect to VCC and DC-

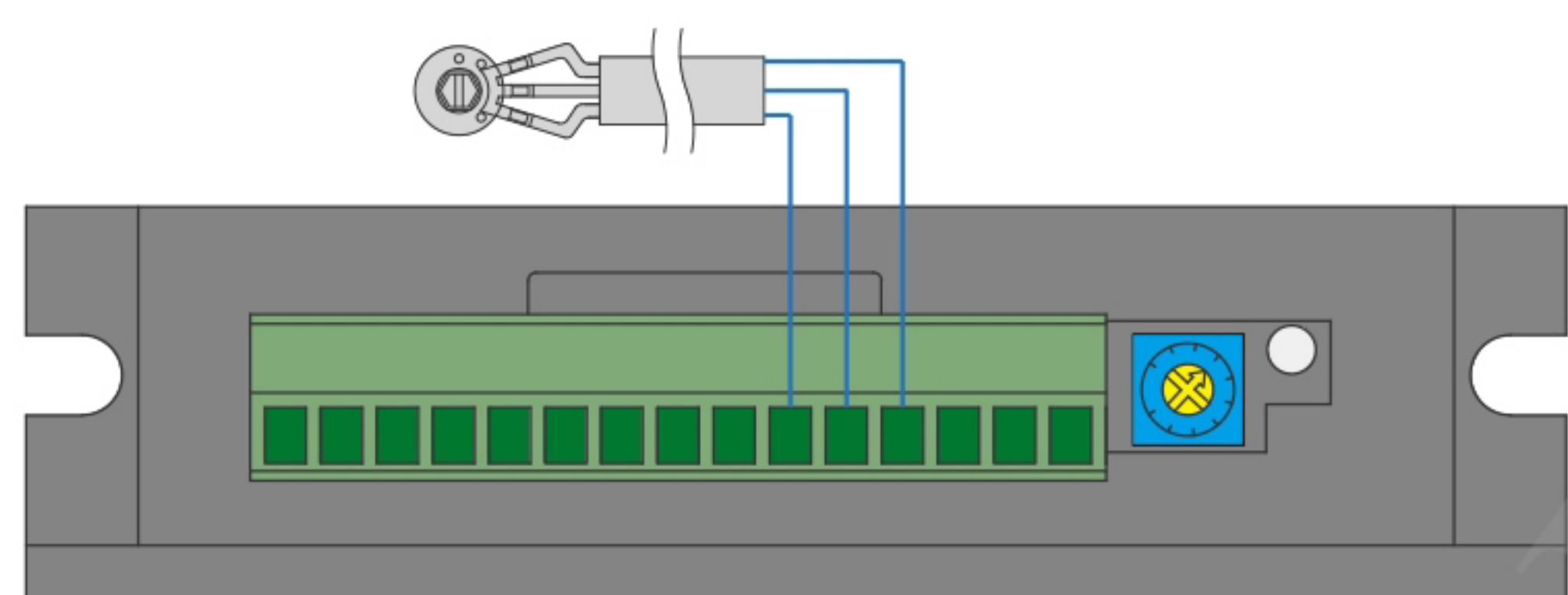

PWM speed setting mode

When customers select PWM speed setting mode, the duty ratio is advised to set as 2%-90%. When duty ratio is 2%, the motor speed reaches 5% of the fastest speed; when the duty ratio is 90%, the motor speed reaches maximum value, which depends on the motor specification and power voltage. (The pulse frequency range: 1-3KHz).



Speed setting via external analog signal

The analog signal voltage can be 0-5VDC; when the voltage is 0.25-4.7VDC, the motor speed reaches 5% of fastest speed: when the voltage is 4.7VDC, the motor speed reaches maximum value, which depends on the motor specification and power voltage.

