

Demension

Brushless

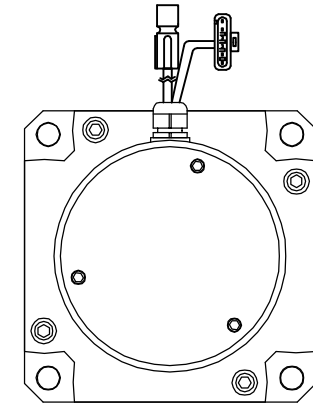

Motor to Hall Relationship

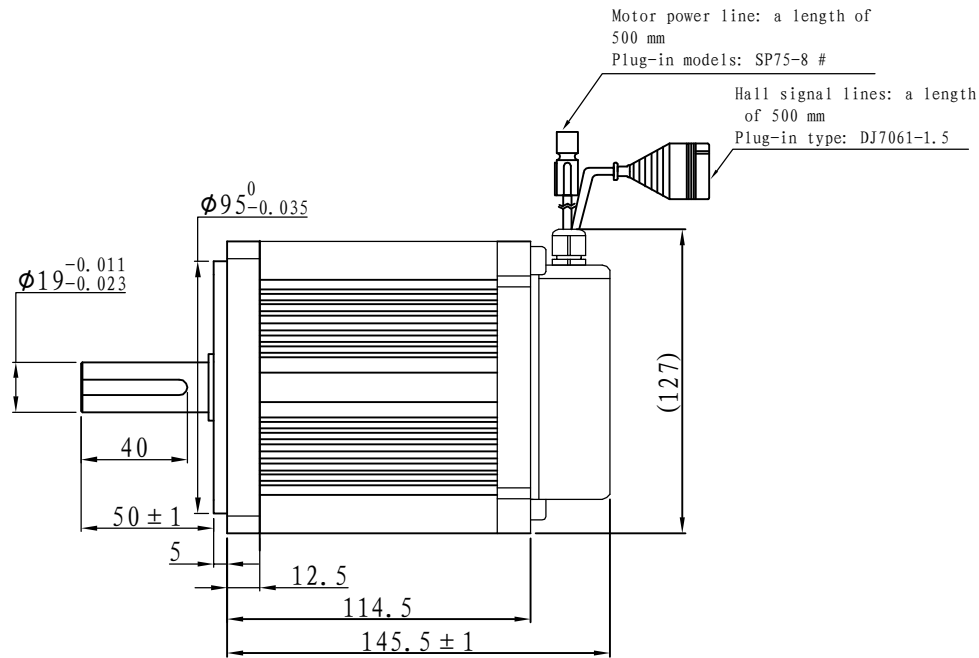
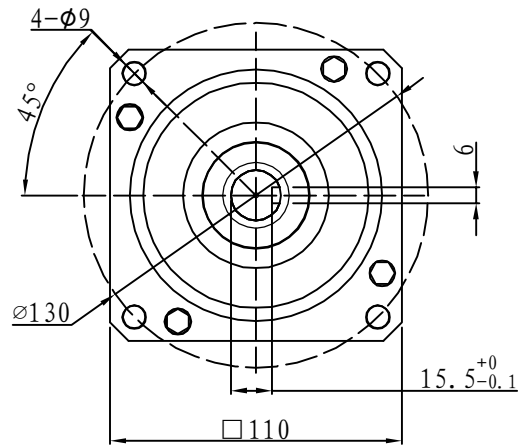
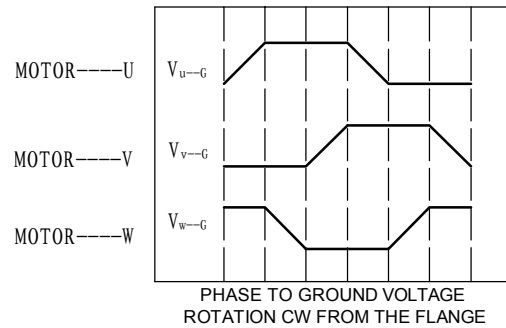
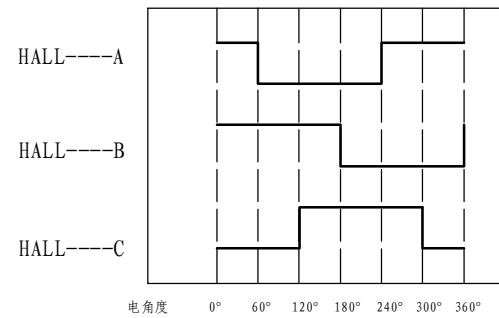

Line Define

Power Wire

Red	Motor U
Yellow	Motor V
Blue	Motor W

Feedback Wire

Hall line colour	Hall signal definition	Plug serial number
Orange and black	5V	1
Orange	0V	2
Yellow	Hall A	4
Blue	Hall B	5
Green	Hall C	6

Tecnichal Data

Type	110WD-M02020-24V
Power (KW)	0.4
Rated voltage (V)	24
Rated current (A)	21.8
Rated speed (rpm)	2000
Rated torque (NM)	2
Rotor inertia (Kgcm ²)	3.3
Protection rank	IP65
Insulation rank	F
Appropriate environment	Temperature: 0 ~ 50°C Humidity: < 90% (No dewdrop)
Motor weight (KG)	3.2

Demension

Brushless

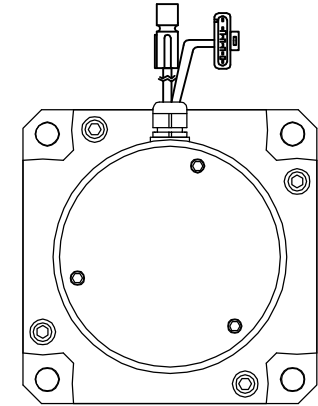
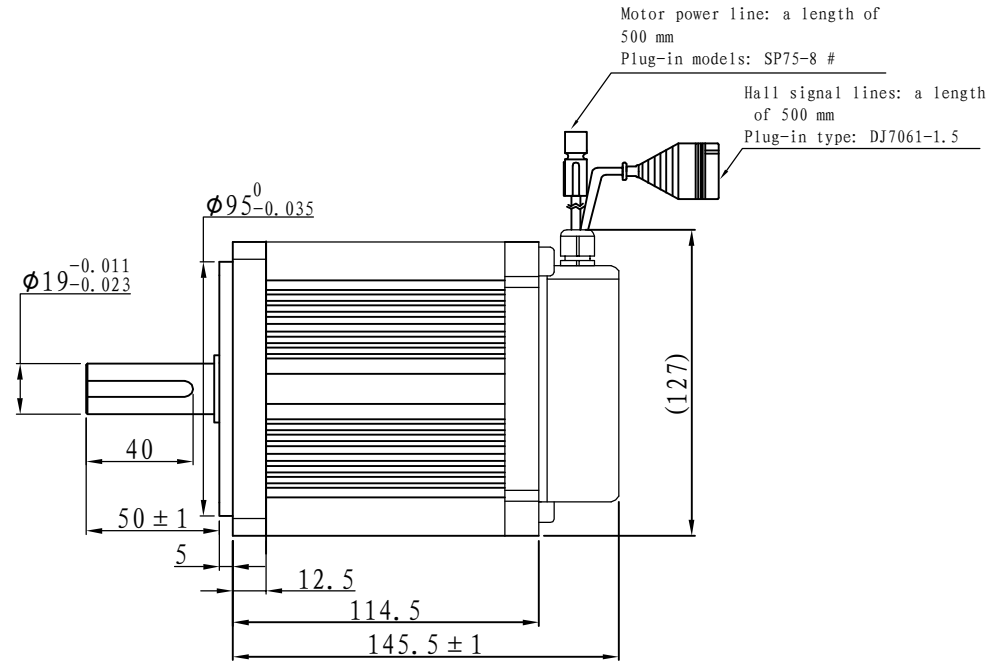
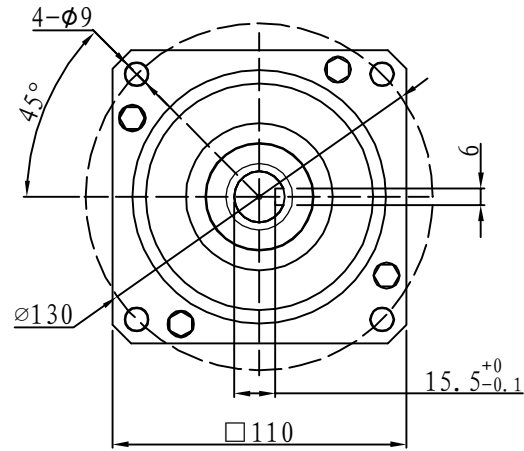

Motor to Hall Relationship

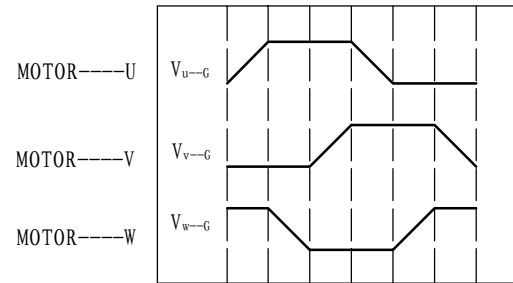
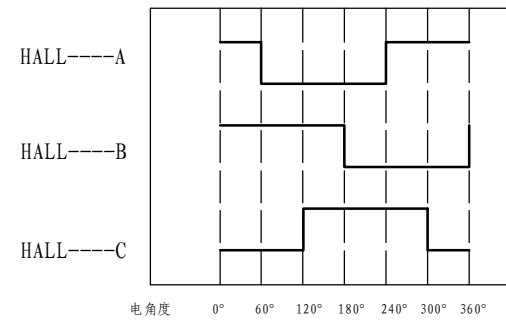

PHASE TO GROUND VOLTAGE
ROTATION CW FROM THE FLANGE

Line Define

Power Wire

Red	Motor U
Yellow	Motor V
Blue	Motor W

Feedback Wire

Hall line colour	Hall signal definition	Plug serial number
Orange and black	5V	1
Orange	0V	2
Yellow	Hall A	3
Blue	Hall B	4
Green	Hall C	5

Tecnichal Data

Type	110WD-M02020-48V
Power (KW)	0.4
Rated voltage (V)	48
Rated current (A)	10.9
Rated speed (rpm)	2000
Rated torque (NM)	2
Rotor inertia (Kgc ^{m2})	3.3
Protection rank	IP65
Insulation rank	F
Appropriate environment	Temperature: 0 ~ 50°C Humidity: < 90% (No dewdrop)
Motor weight (KG)	3.2

Demension

Brushless

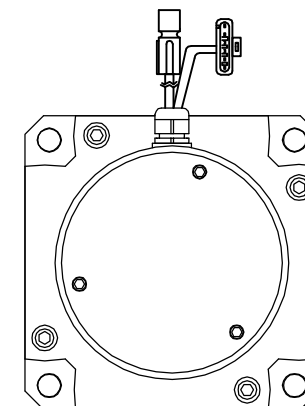
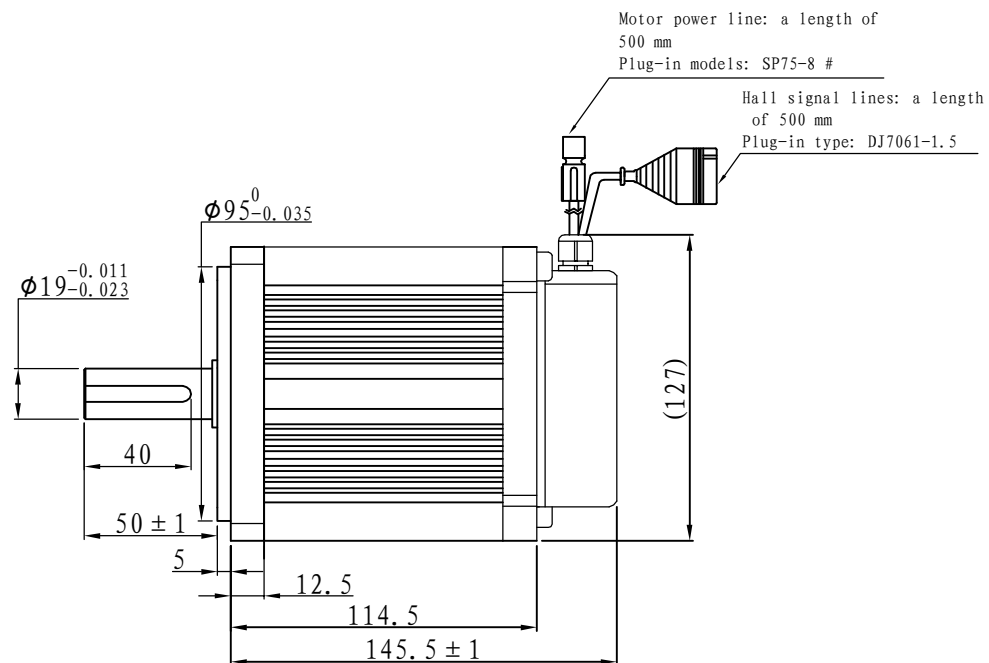
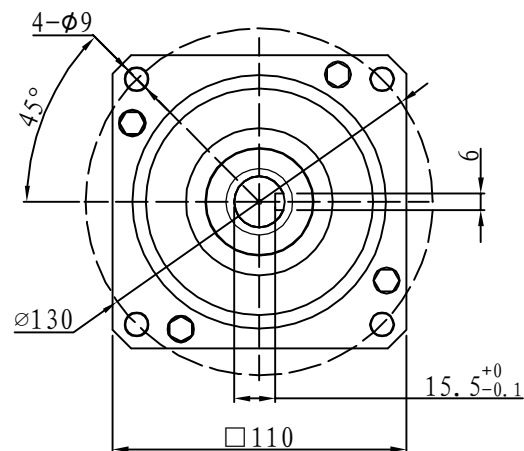

Motor to Hall Relationship

Line Define

Tecnichal Data

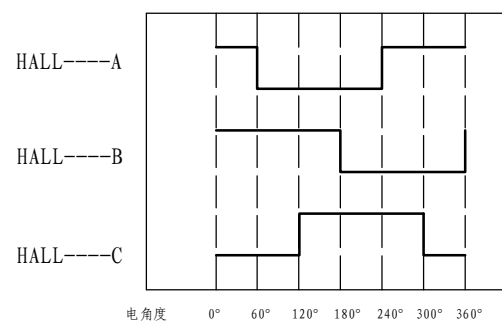

Power Wire

Red	Motor U
Yellow	Motor V
Blue	Motor W

Feedback Wire

Hall line colour	Hall signal definition	Plug serial number
Orange and black	5V	1
Orange	0V	2
Yellow	Hall A	3
Blue	Hall B	4
Green	Hall C	5

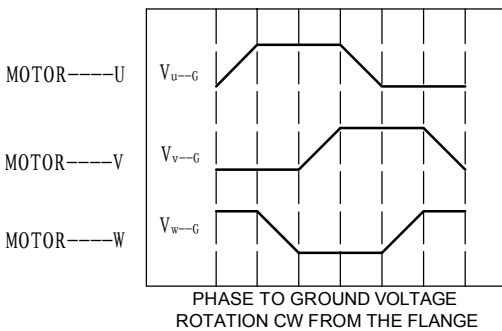

Type	110WD-M02020-72V
Power (KW)	0.4
Rated voltage (V)	72
Rated current (A)	7.3
Rated speed (rpm)	2000
Rated torque (NM)	2
Rotor inertia (Kgc ²)	3.3
Protection rank	IP65
Insulation rank	F
Appropriate environment	Temperature: 0 ~ 50°C Humidity: < 90% (No dewdrop)
Motor weight (KG)	3.2

Demension

Brushless

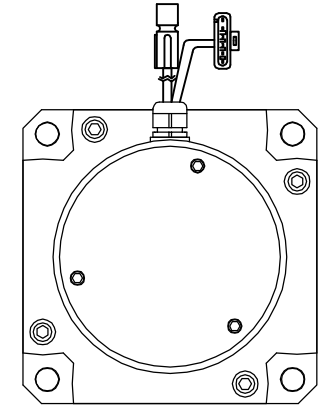
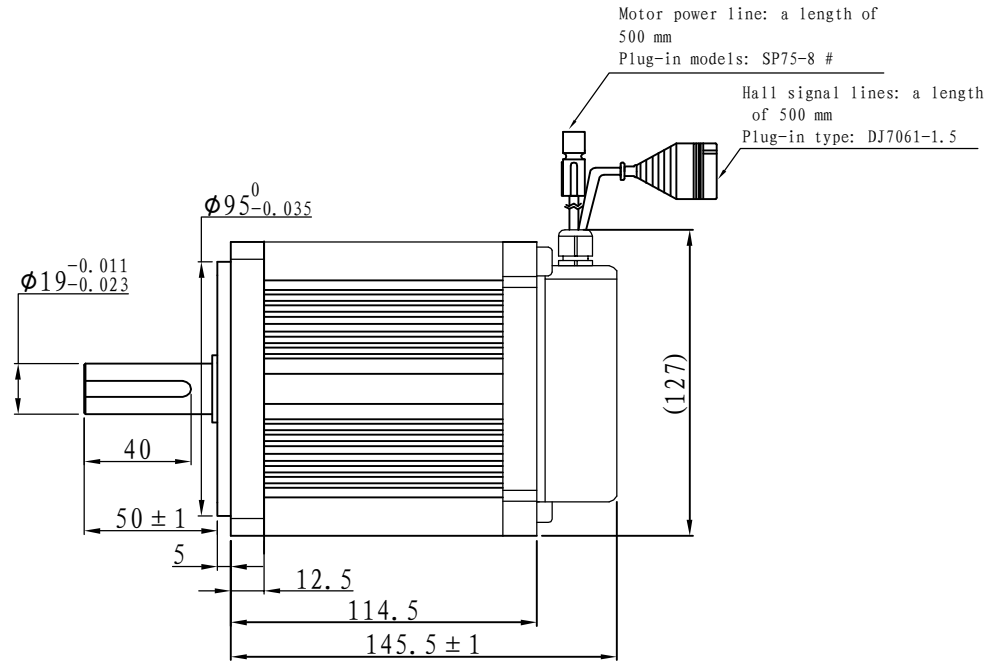
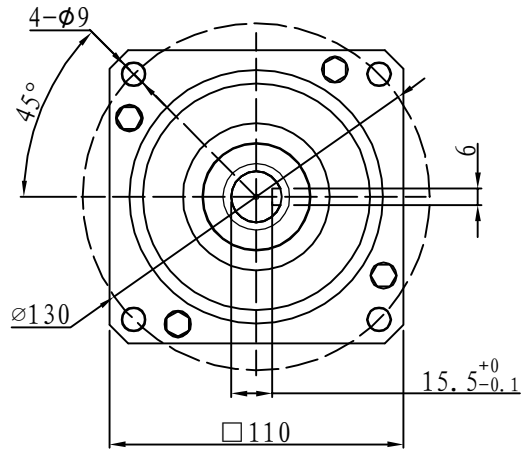

Motor to Hall Relationship

Line Define

Tecnichal Data

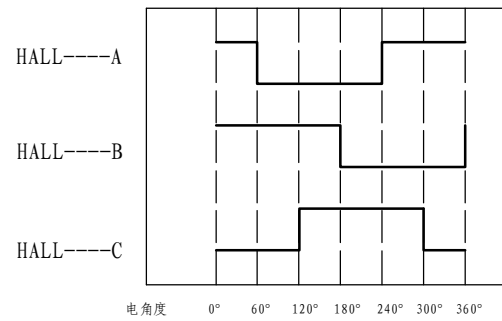

Power Wire

Feedback Wire

Red	Motor U
Yellow	Motor V
Blue	Motor W

Hall line colour	Hall signal definition	Plug serial number
Orange and black	5V	1
Orange	0V	2
Yellow	Hall A	3
Blue	Hall B	4
Green	Hall C	5

Type	110WD-M02020-96V
Power (KW)	0.4
Rated voltage (V)	96
Rated current (A)	5.5
Rated speed (rpm)	2000
Rated torque (NM)	2
Rotor inertia (Kgc ^{m2})	3.3
Protection rank	IP65
Insulation rank	F
Appropriate environment	Temperature: 0 ~ 50°C Humidity: < 90% (No dewdrop)
Motor weight (KG)	3.2

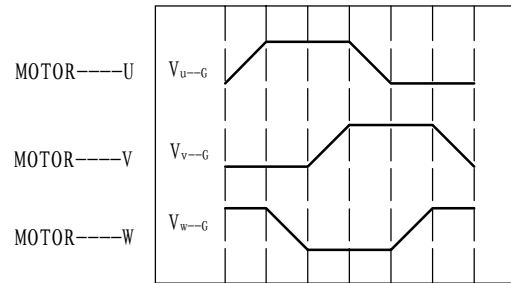

PHASE TO GROUND VOLTAGE
ROTATION CW FROM THE FLANGE