

# Demension

# Brushless

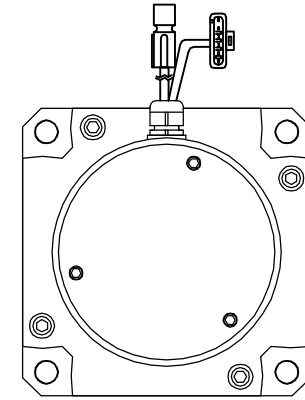

## Motor to Hall Relationship

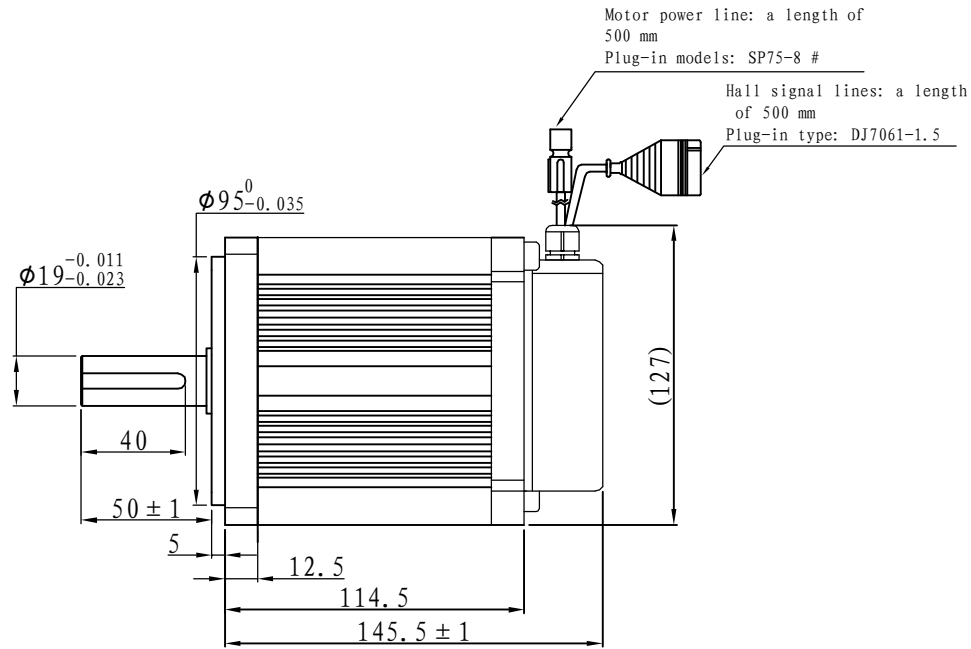
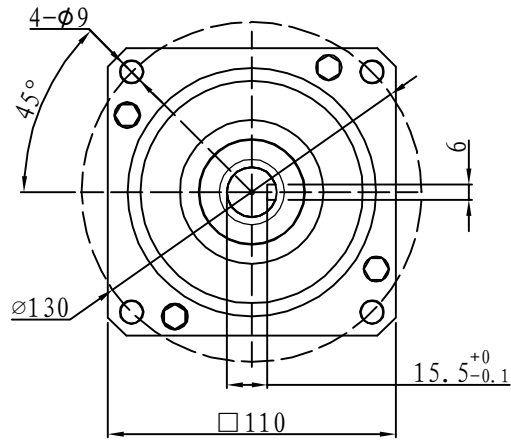
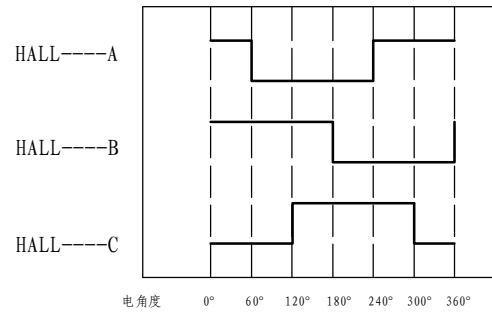

电角度 0° 60° 120° 180° 240° 300° 360°

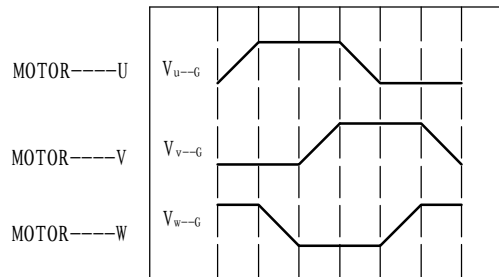

PHASE TO GROUND VOLTAGE  
ROTATION CW FROM THE FLANGE

## Line Define

### Power Wire

Red	Motor U
Yellow	Motor V
Blue	Motor W

### Feedback Wire

Hall line colour	Hall signal definition	Plug serial number
Orange and black	5V	1
Orange	0V	2
Yellow	Hall A	4
Blue	Hall B	5
Green	Hall C	6

## Tecnichal Data

Type	110WD-M02030-24V
Power (KW)	0.6
Rated voltage (V)	24
Rated current (A)	32.7
Rated speed (rpm)	3000
Rated torque (NM)	2
Rotor inertia (KgcM2)	3.3
Protection rank	IP65
Insulation rank	F
Appropriate environment	Temperature: 0 ~ 50°C Humidity: <90% (No dewdrop)
Motor weight (KG)	3.2

# Demension

# Brushless

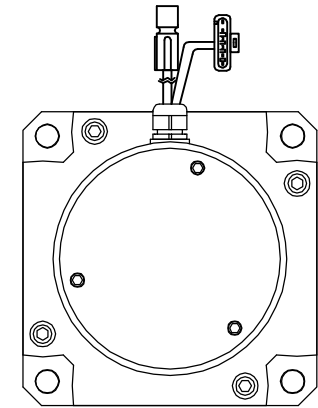
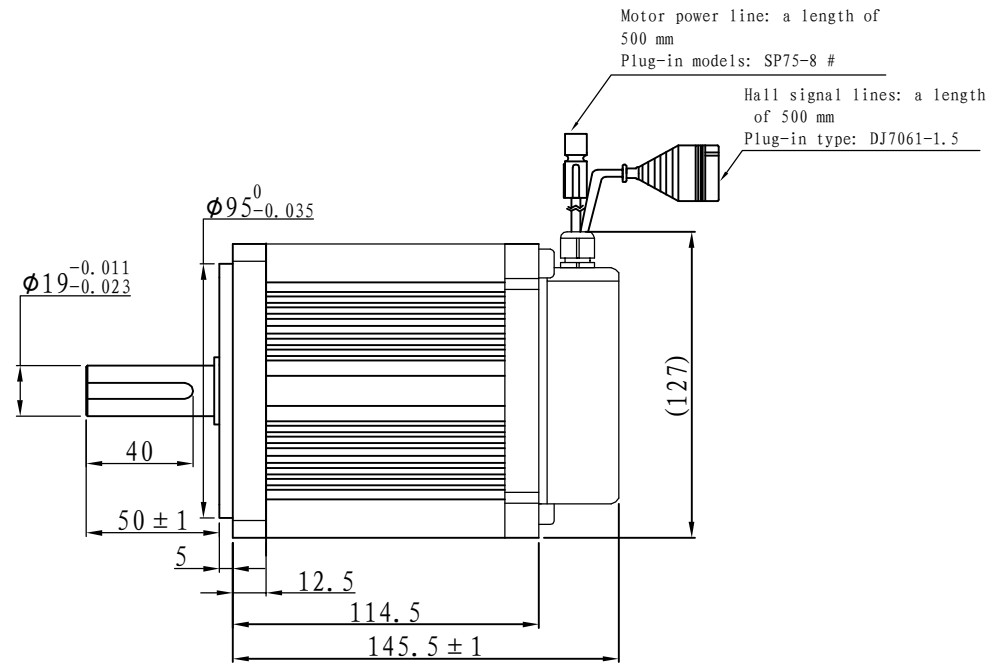
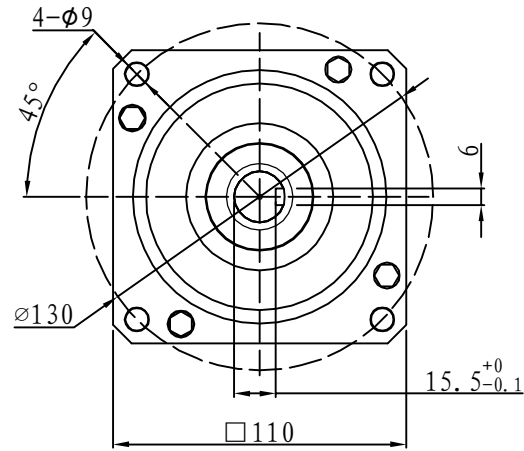

## Motor to Hall Relationship

## Line Define

## Tecnichal Data

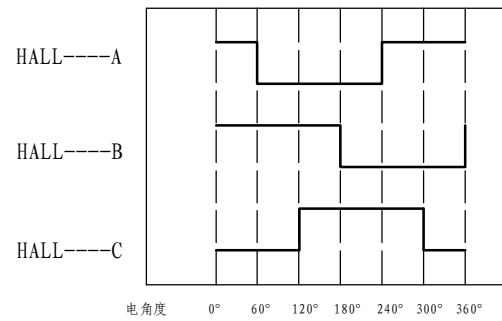

### Power Wire

Red	Motor U
Yellow	Motor V
Blue	Motor W

### Feedback Wire

Hall line colour	Hall signal definition	Plug serial number
Orange and black	5V	1
Orange	0V	2
Yellow	Hall A	3
Blue	Hall B	4
Green	Hall C	5

Type	110WD-M02030-48V
Power (KW)	0.6
Rated voltage (V)	48
Rated current (A)	16.4
Rated speed (rpm)	3000
Rated torque (NM)	2
Rotor inertia (Kgc <sup>m2</sup> )	3.3
Protection rank	IP65
Insulation rank	F
Appropriate environment	<b>Temperature: 0 ~ 50°C</b> <b>Humidity: &lt; 90%</b> <b>(No dewdrop)</b>
Motor weight (KG)	3.2

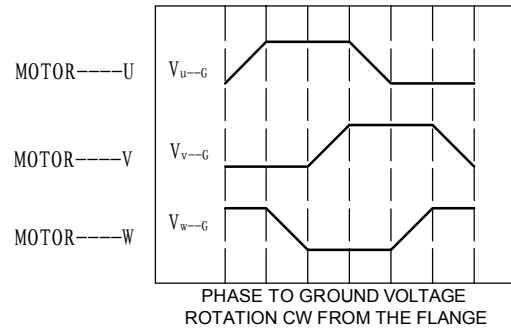

# Demension

# Brushless

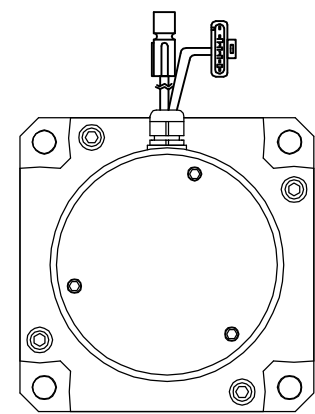
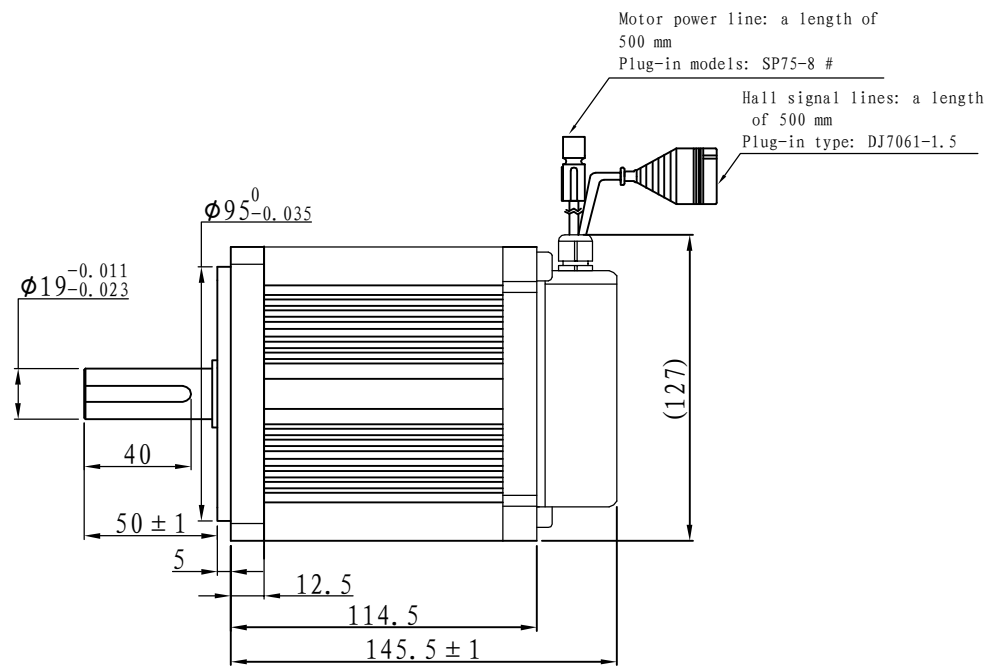
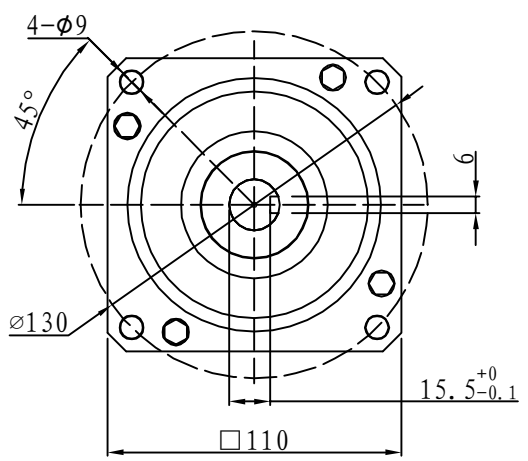

## Motor to Hall Relationship

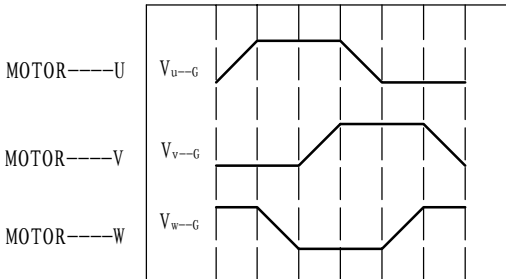
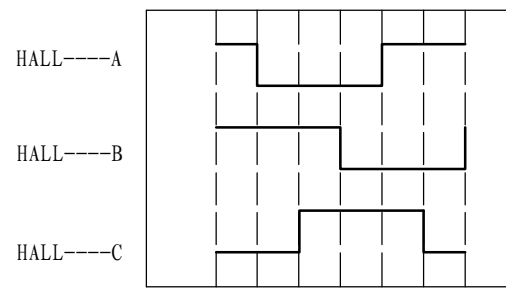

PHASE TO GROUND VOLTAGE  
ROTATION CW FROM THE FLANGE

## Line Define

Power Wire	
Red	Motor U
Yellow	Motor V
Blue	Motor W

Feedback Wire		
Hall line colour	Hall signal definition	Plug serial number
Orange and black	5V	1
Orange	0V	2
Yellow	Hall A	3
Blue	Hall B	4
Green	Hall C	5

## Tecnichal Data

Type	110WD-M02030-72V
Power (KW)	0.6
Rated voltage (V)	72
Rated current (A)	10.9
Rated speed (rpm)	3000
Rated torque (NM)	2
Rotor inertia (Kgc <sup>m2</sup> )	3.3
Protection rank	IP65
Insulation rank	F
Appropriate environment	Temperature: 0 ~ 50°C Humidity: < 90% (No dewdrop)
Motor weight (KG)	3.2

# Demension

# Brushless

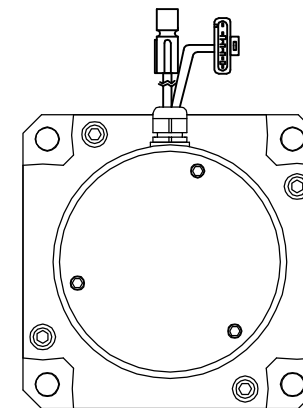
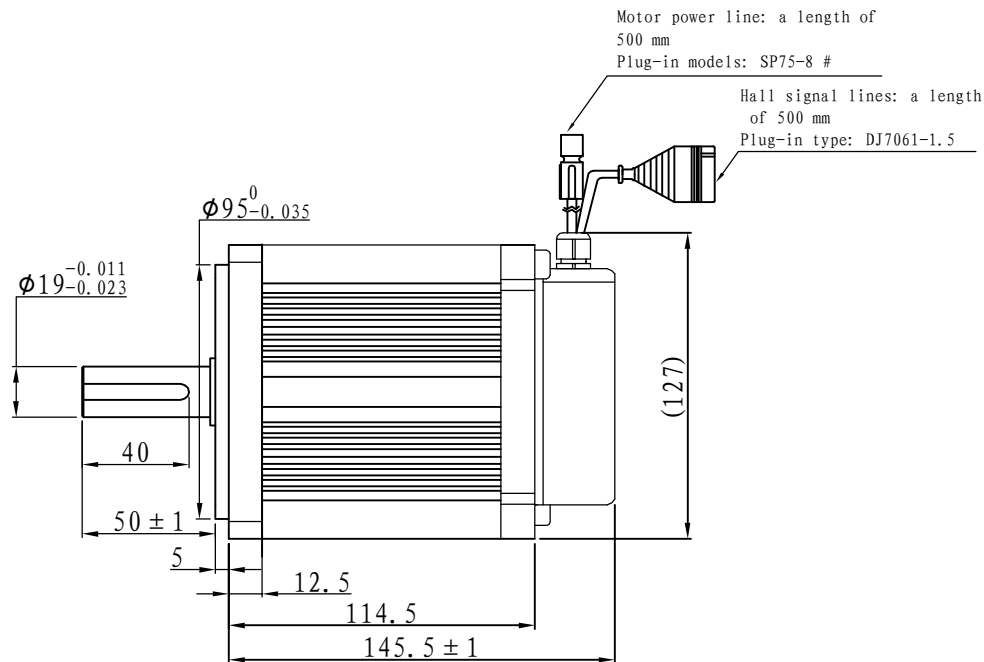
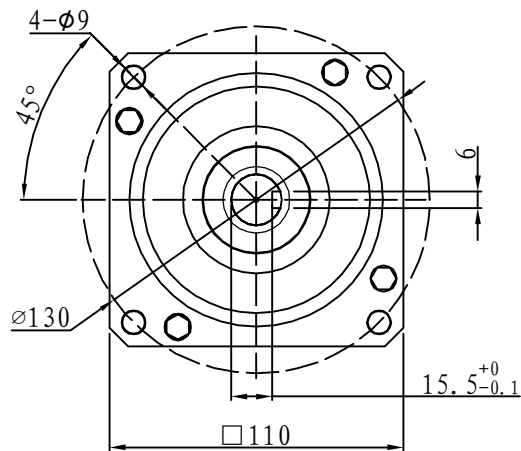

## Motor to Hall Relationship

## Line Define

## Tecnichal Data

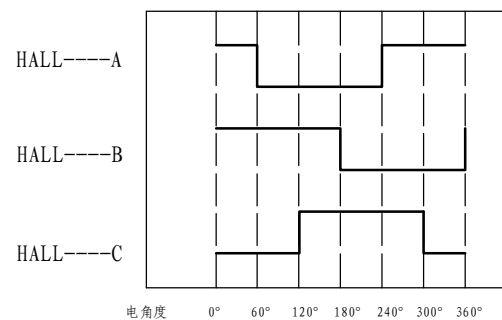

## Power Wire

## Feedback Wire

Red	Motor U
Yellow	Motor V
Blue	Motor W

Hall line colour	Hall signal definition	Plug serial number
Orange and black	5V	1
Orange	0V	2
Yellow	Hall A	3
Blue	Hall B	4
Green	Hall C	5

Type	110WD-M02030-96V
Power (KW)	0.6
Rated voltage (V)	96
Rated current (A)	8.2
Rated speed (rpm)	3000
Rated torque (NM)	2
Rotor inertia (Kgc <sup>m</sup> 2)	3.3
Protection rank	IP65
Insulation rank	F
Appropriate environment	<b>Temperature: 0 ~ 50°C</b> <b>Humidity: &lt; 90%</b> <b>(No dewdrop)</b>
Motor weight (KG)	3.2

