

Demension

Brushless

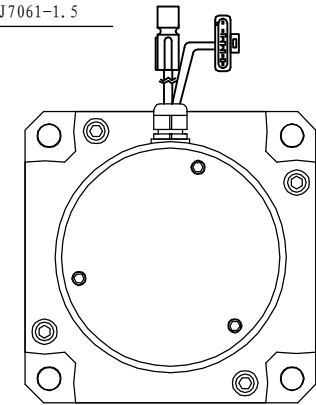

Motor to Hall Relationship

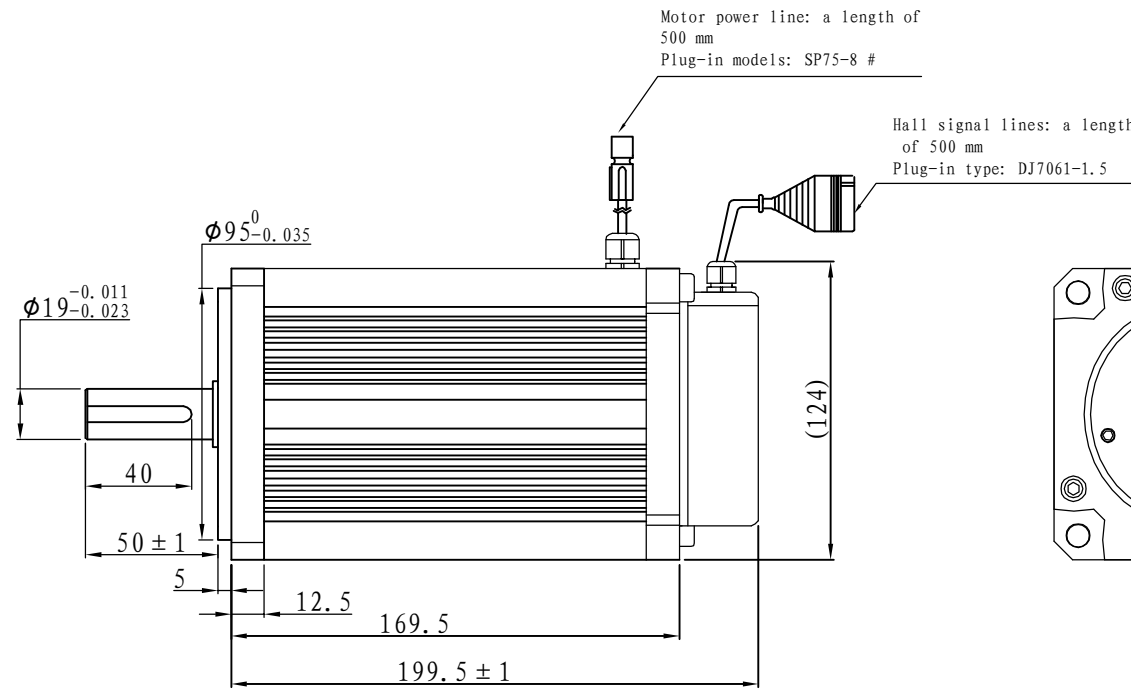
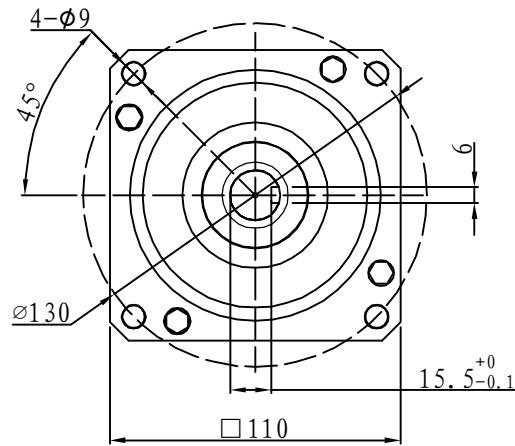
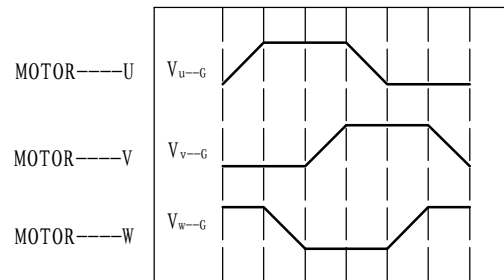
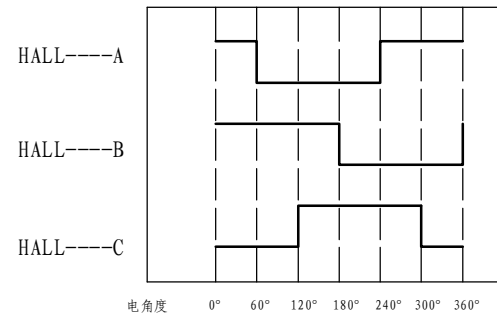

PHASE TO GROUND VOLTAGE
ROTATION CW FROM THE FLANGE

Line Define

Power Wire

Red	Motor U
Yellow	Motor V
Blue	Motor W

Feedback Wire

Hall line colour	Hall signal definition	Plug serial number
Orange and black	5V	1
Orange	0V	2
Yellow	Hall A	4
Blue	Hall B	5
Green	Hall C	6

Tecnichal Data

Type	110WD-M04030-24V
Power (KW)	1.3
Rated voltage (V)	24
Rated current (A)	65.4
Rated speed (rpm)	3000
Rated torque (NM)	4
Rotor inertia (Kgcm2)	6.5
Protection rank	IP65
Insulation rank	F
Appropriate environment	Temperature: 0~50°C Humidity: <90% (No dewdrop)
Motor weight (KG)	5.65

Demension

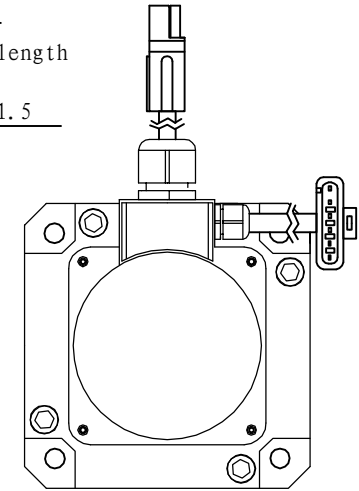
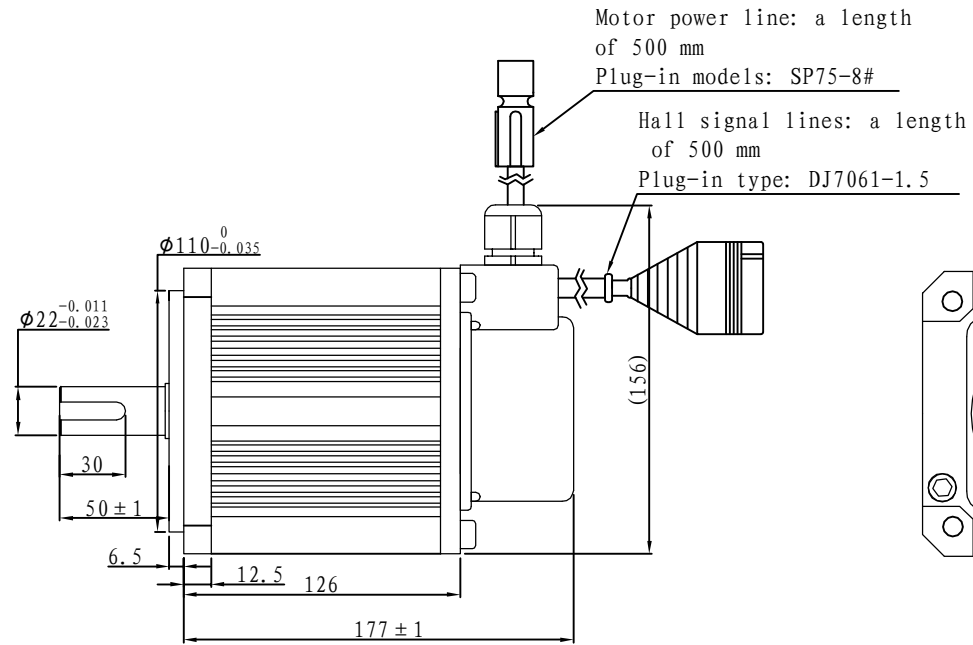
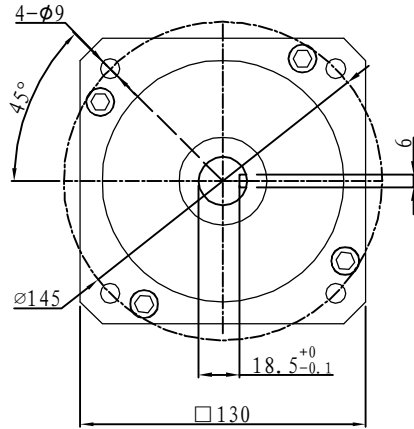

Brushless

Motor to Hall Relationship

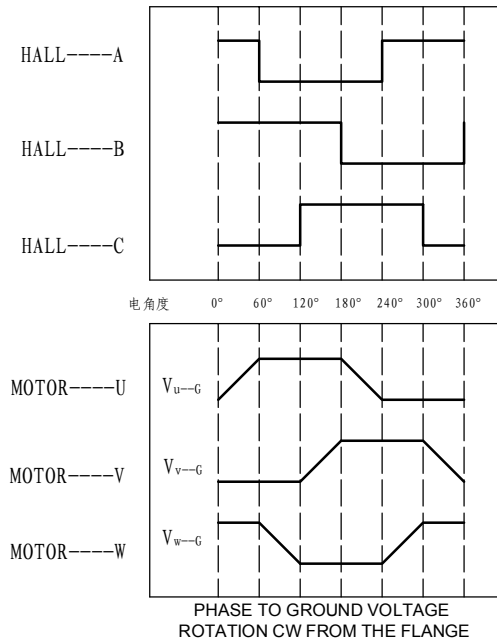

Line Define

Power Wire

Red	Motor U
Yellow	Motor V
Blue	Motor W

Feedback Wire

Hall line colour	Hall signal definition	Plug serial number
Orange and black	5V	1
Orange	0V	2
Yellow	Hall A	4
Blue	Hall B	5
Green	Hall C	6

Tecnichal Data

Type	130WD-M04030-48V
Power (KW)	1.3
Rated voltage (V)	48
Rated current (A)	30.8
Rated speed (rpm)	3000
Rated torque (NM)	4
Rotor inertia (Kgc ^m 2)	10.4
Protection rank	IP65
Insulation rank	F
Appropriate environment	Temperature: 0~50°C Humidity: <90% (No dewdrop)
Motor weight (KG)	6.7

Demension

Brushless

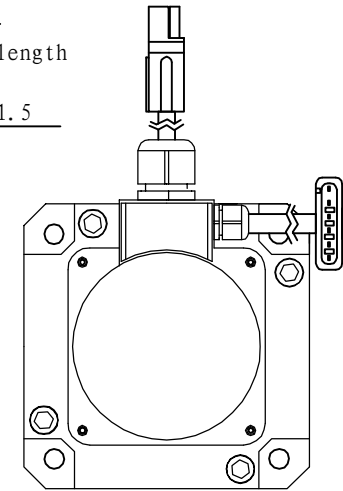
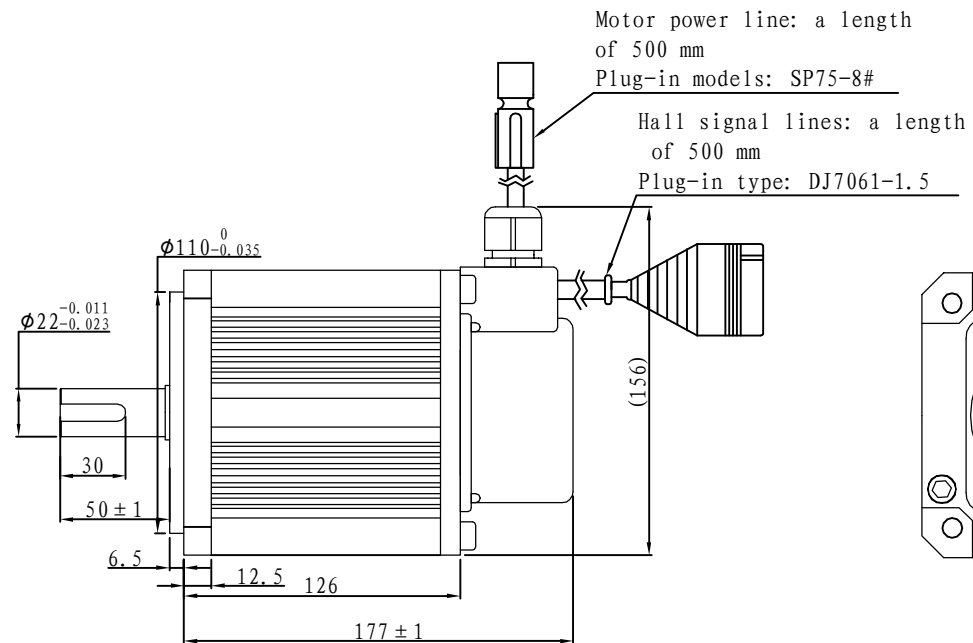
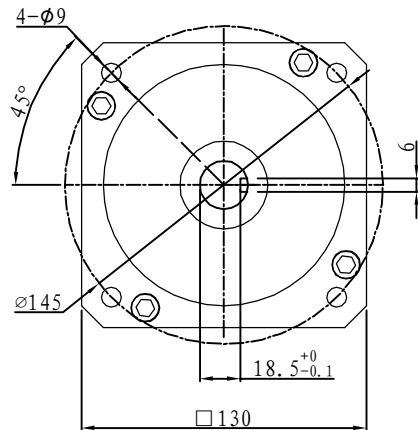

Motor to Hall Relationship

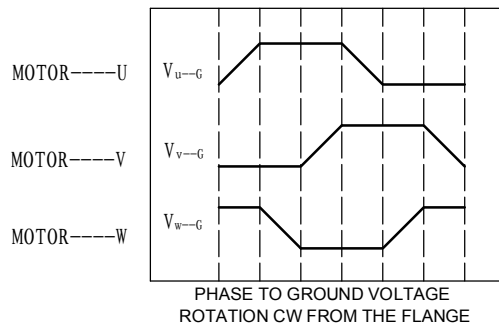
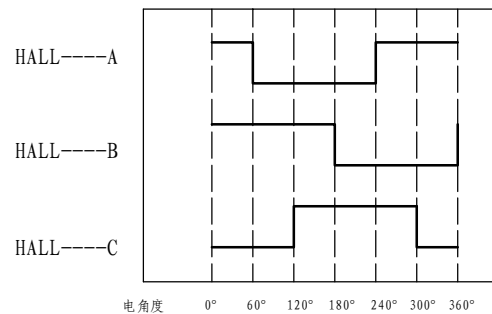

Line Define

Power Wire

Red	Motor U
Yellow	Motor V
Blue	Motor W

Feedback Wire

Hall line colour	Hall signal definition	Plug serial number
Orange and black	5V	1
Orange	0V	2
Yellow	Hall A	4
Blue	Hall B	5
Green	Hall C	6

Tecnichal Data

Type	130WD-M04030-72V
Power (KW)	1.3
Rated voltage (V)	72
Rated current (A)	20.5
Rated speed (rpm)	3000
Rated torque (NM)	4
Rotor inertia (Kgc ^m 2)	10.4
Protection rank	IP65
Insulation rank	F
Appropriate environment	Temperature: 0~50°C Humidity: <90% (No dewdrop)
Motor weight (KG)	6.7

Demension

Brushless

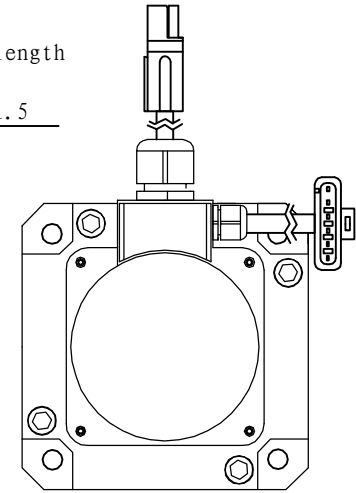
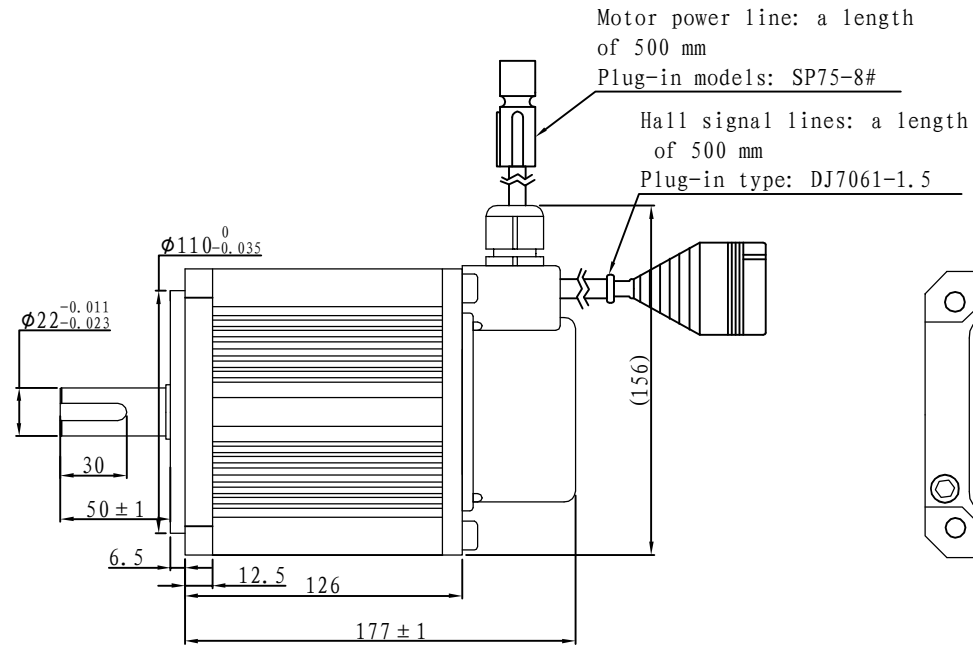
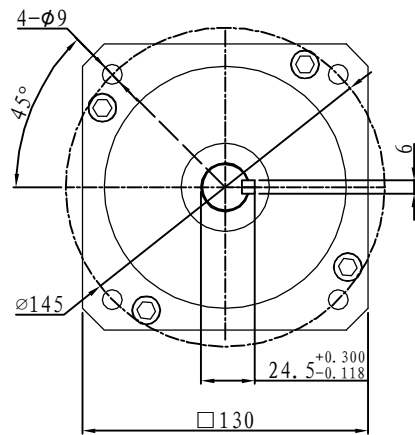

Motor to Hall Relationship

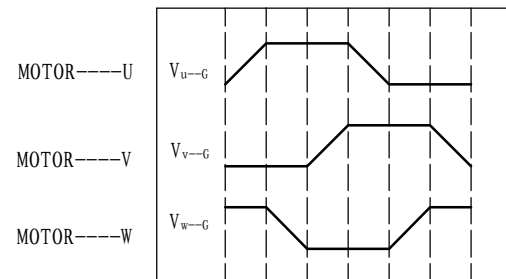
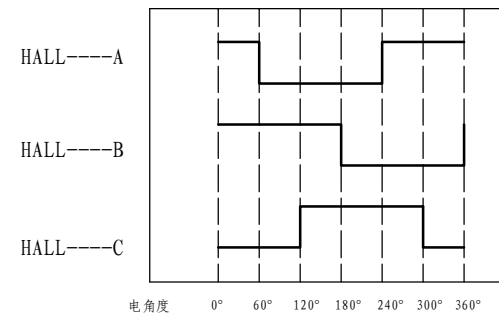

PHASE TO GROUND VOLTAGE
ROTATION CW FROM THE FLANGE

Line Define

Power Wire

Red	Motor U
Yellow	Motor V
Blue	Motor W

Feedback Wire

Hall line colour	Hall signal definition	Plug serial number
Orange and black	5V	1
Orange	0V	2
Yellow	Hall A	4
Blue	Hall B	5
Green	Hall C	6

Tecnichal Data

Type	130WD-M04030-96V
Power (KW)	1.3
Rated voltage (V)	96
Rated current (A)	15.4
Rated speed (rpm)	3000
Rated torque (NM)	4
Rotor inertia (Kgcm ²)	10.4
Protection rank	IP65
Insulation rank	F
Appropriate environment	Temperature: 0~50°C Humidity: <90% (No dewdrop)
Motor weight (KG)	6.7