

Demension

Brushless

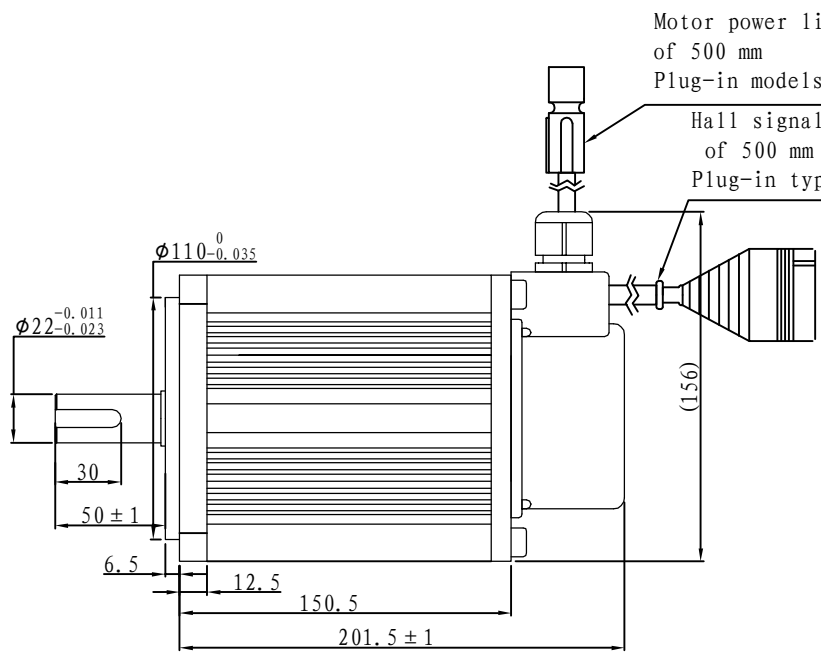

Motor power line: a length of 500 mm
 Plug-in models: SP75-8#
 Hall signal lines: a length of 500 mm
 Plug-in type: DJ7061-1.5

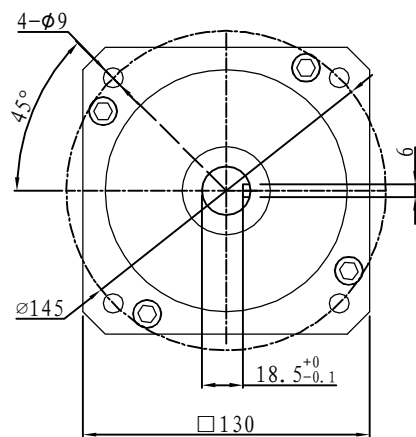
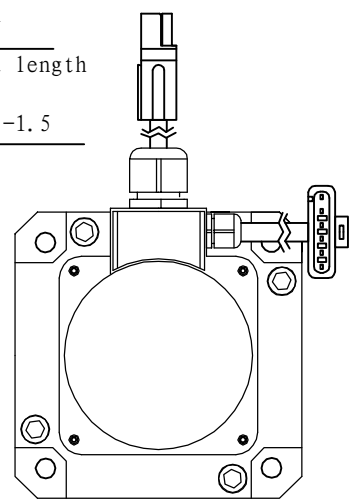

Motor to Hall Relationship

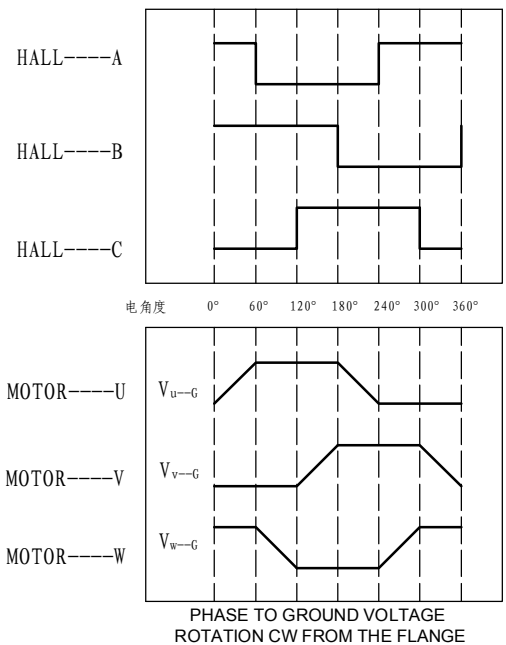

Line Define

Power Wire

Red	Motor U
Yellow	Motor V
Blue	Motor W

Feedback Wire

Hall line colour	Hall signal definition	Plug serial number
Orange and black	5V	1
Orange	0V	2
Yellow	Hall A	4
Blue	Hall B	5
Green	Hall C	6

Tecnichal Data

Type	130WD-M07730-48V
Power (KW)	2.4
Rated voltage (V)	48
Rated current (A)	59.3
Rated speed (rpm)	3000
Rated torque (NM)	7.7
Rotor inertia (Kgcm ²)	15.8
Protection rank	IP65
Insulation rank	F
Appropriate environment	Temperature: 0 ~ 50°C Humidity: < 90% (No dewdrop)
Motor weight (KG)	9.05

Demension

Brushless

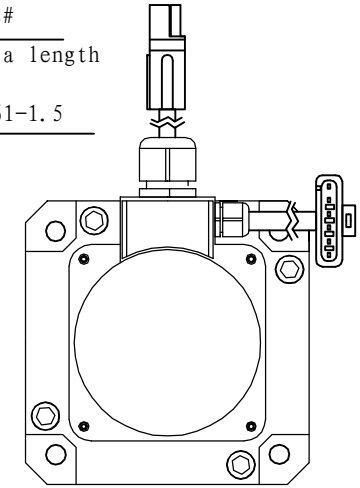
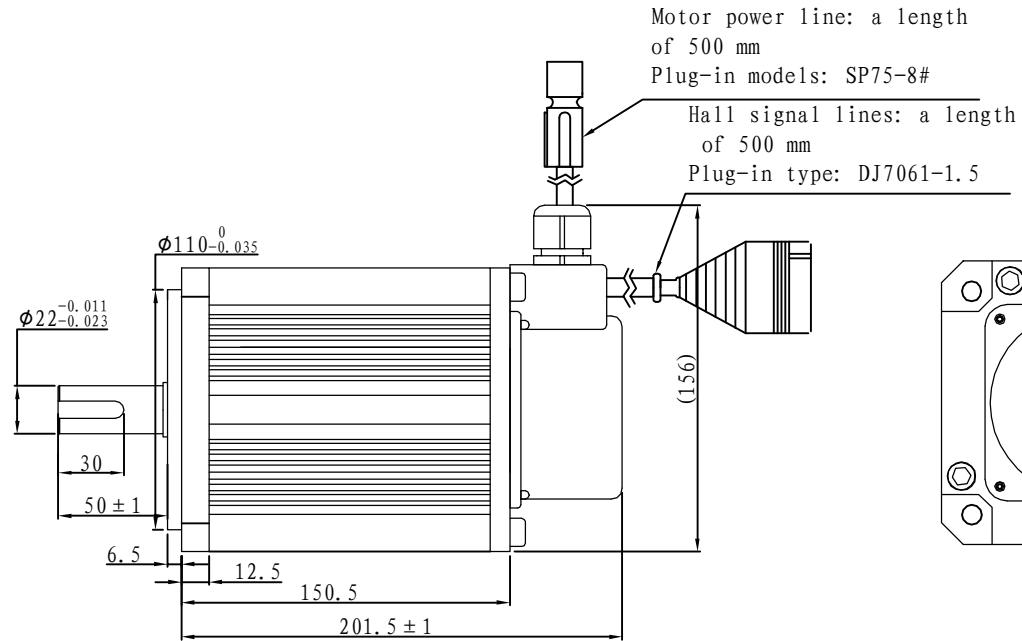
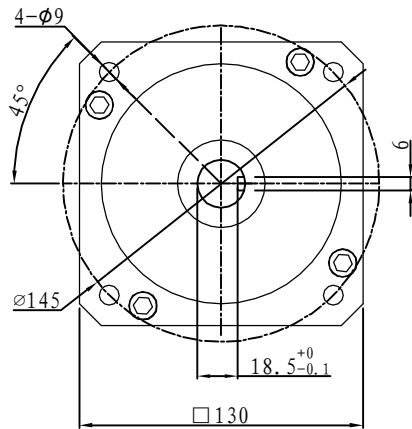

Motor to Hall Relationship

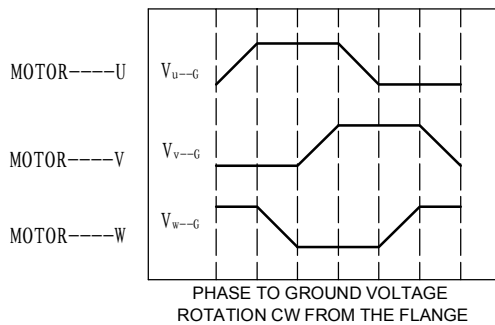
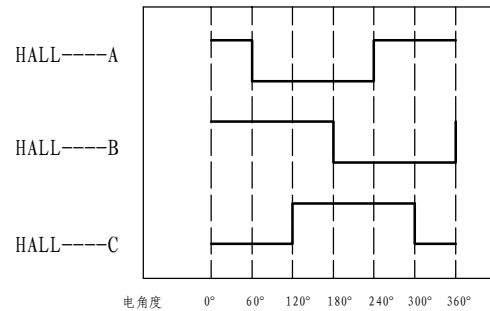

Line Define

Power Wire

Red	Motor U
Yellow	Motor V
Blue	Motor W

Feedback Wire

Hall line colour	Hall signal definition	Plug serial number
Orange and black	5V	1
Orange	0V	2
Yellow	Hall A	4
Blue	Hall B	5
Green	Hall C	6

Tecnichal Data

Type	130WD-M07730-72V
Power (KW)	2.4
Rated voltage (V)	72
Rated current (A)	39.5
Rated speed (rpm)	3000
Rated torque (NM)	7.7
Rotor inertia (Kgcm ²)	15.8
Protection rank	IP65
Insulation rank	F
Appropriate environment	Temperature: 0 ~ 50°C Humidity: <90% (No dewdrop)
Motor weight (KG)	9.05

Demension

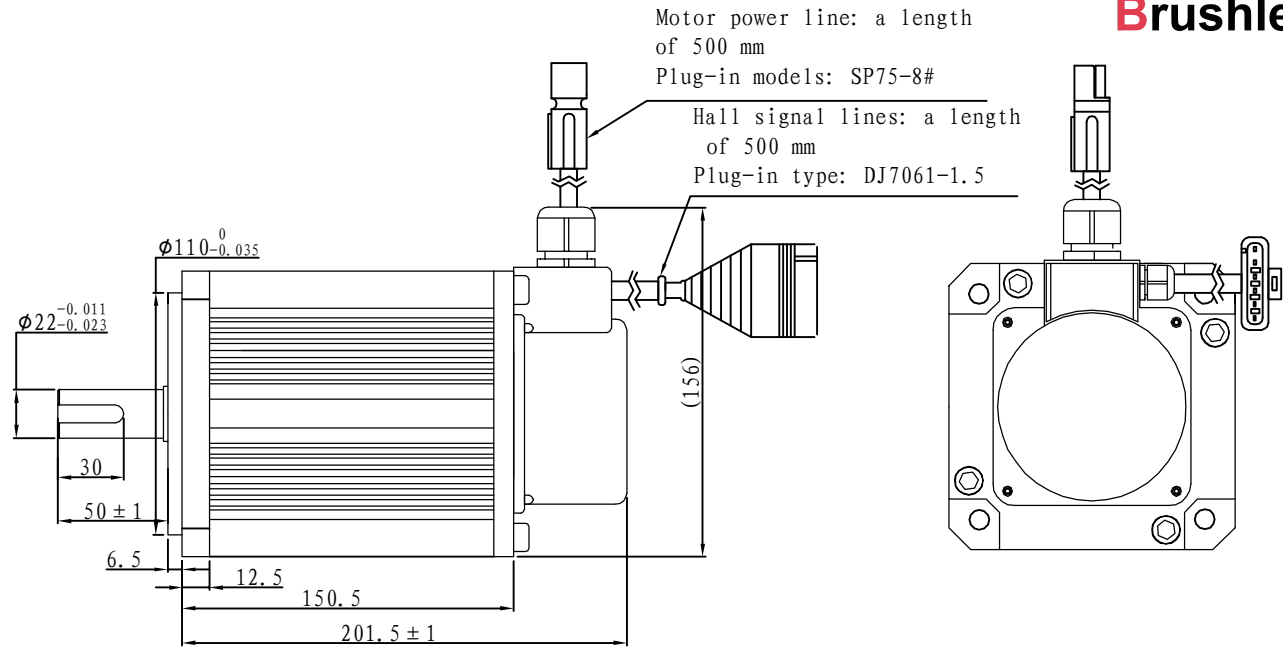
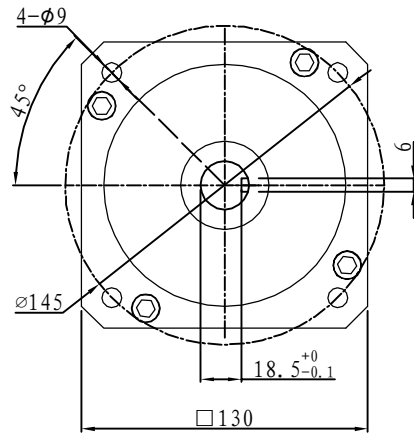

Brushless

Motor to Hall Relationship

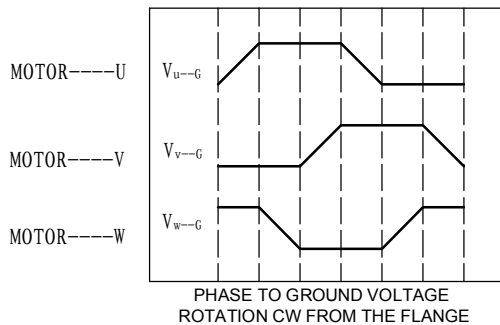
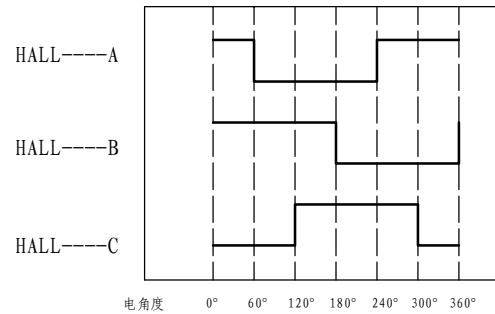

Line Define

Power Wire

Red	Motor U
Yellow	Motor V
Blue	Motor W

Feedback Wire

Hall line colour	Hall signal definition	Plug serial number
Orange and black	5V	1
Orange	0V	2
Yellow	Hall A	4
Blue	Hall B	5
Green	Hall C	6

Technical Data

Type	130WD-M07730-96V
Power (KW)	2.4
Rated voltage (V)	96
Rated current (A)	29.6
Rated speed (rpm)	3000
Rated torque (NM)	7.7
Rotor inertia (Kgcm ²)	15.8
Protection rank	IP65
Insulation rank	F
Appropriate environment	Temperature: 0 ~ 50°C Humidity: < 90% (No dewdrop)
Motor weight (KG)	9.05