

### Demension

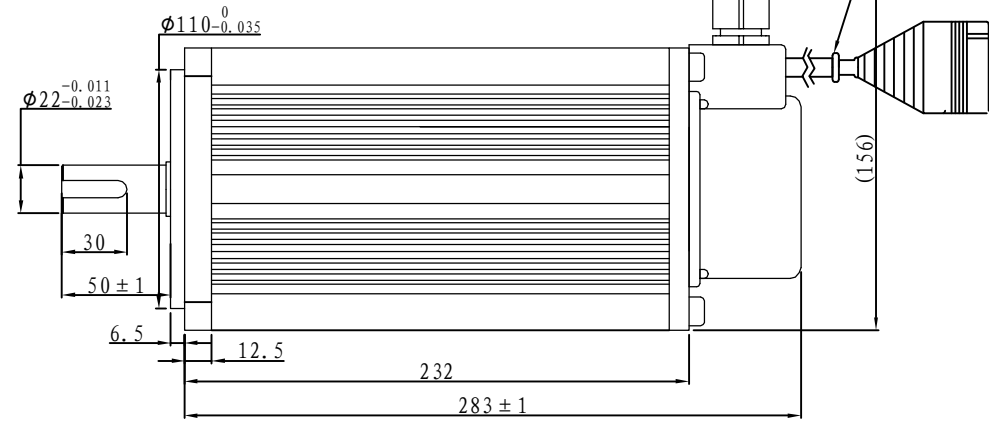

Motor power line: a length of 500 mm  
 Plug-in models: SP75-8#  
 Hall signal lines: a length of 500 mm  
 Plug-in type: DJ7061-1.5

# Brushless

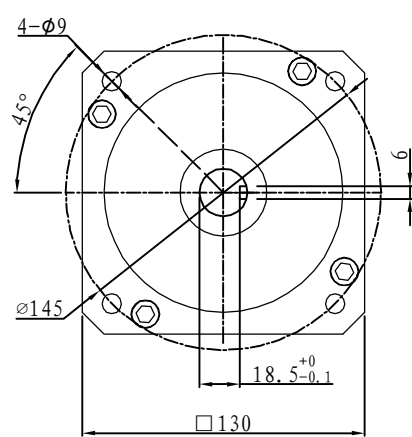
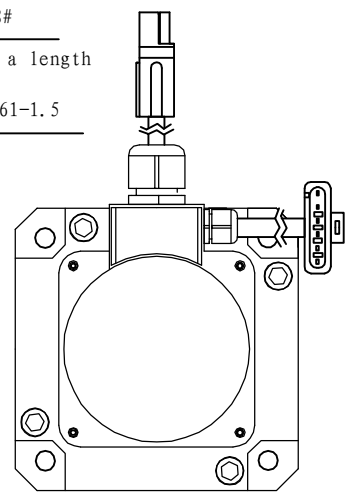

### Motor to Hall Relationship

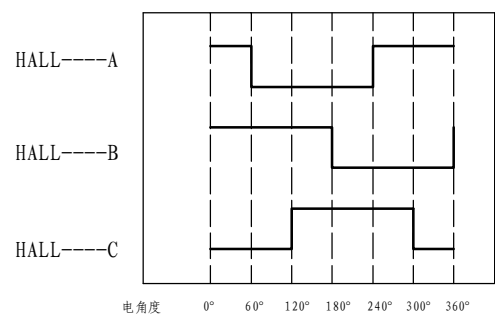

### Line Define

Power Wire	
Red	Motor U
Yellow	Motor V
Blue	Motor W

### Feedback Wire

Hall line colour	Hall signal definition	Plug serial number
Orange and black	5V	1
Orange	0V	2
Yellow	Hall A	4
Blue	Hall B	5
Green	Hall C	6

### Tecnichal Data

Type	130WD-M15030-48V
Power (KW)	4.7
Rated voltage (V)	48
Rated current (A)	115.5
Rated speed (rpm)	3000
Rated torque (NM)	15
Rotor inertia (Kgcm <sup>2</sup> )	32.4
Protection rank	IP65
Insulation rank	F
Appropriate environment	Temperature: 0 ~ 50°C Humidity: < 90% (No dewdrop)
Motor weight (KG)	12

MOTOR---U  
 MOTOR---V  
 MOTOR---W

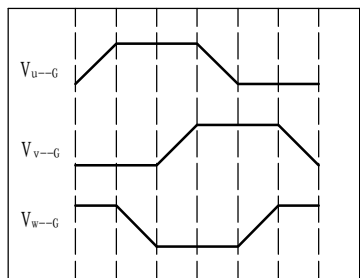

PHASE TO GROUND VOLTAGE  
 ROTATION CW FROM THE FLANGE

# Demension

# Brushless

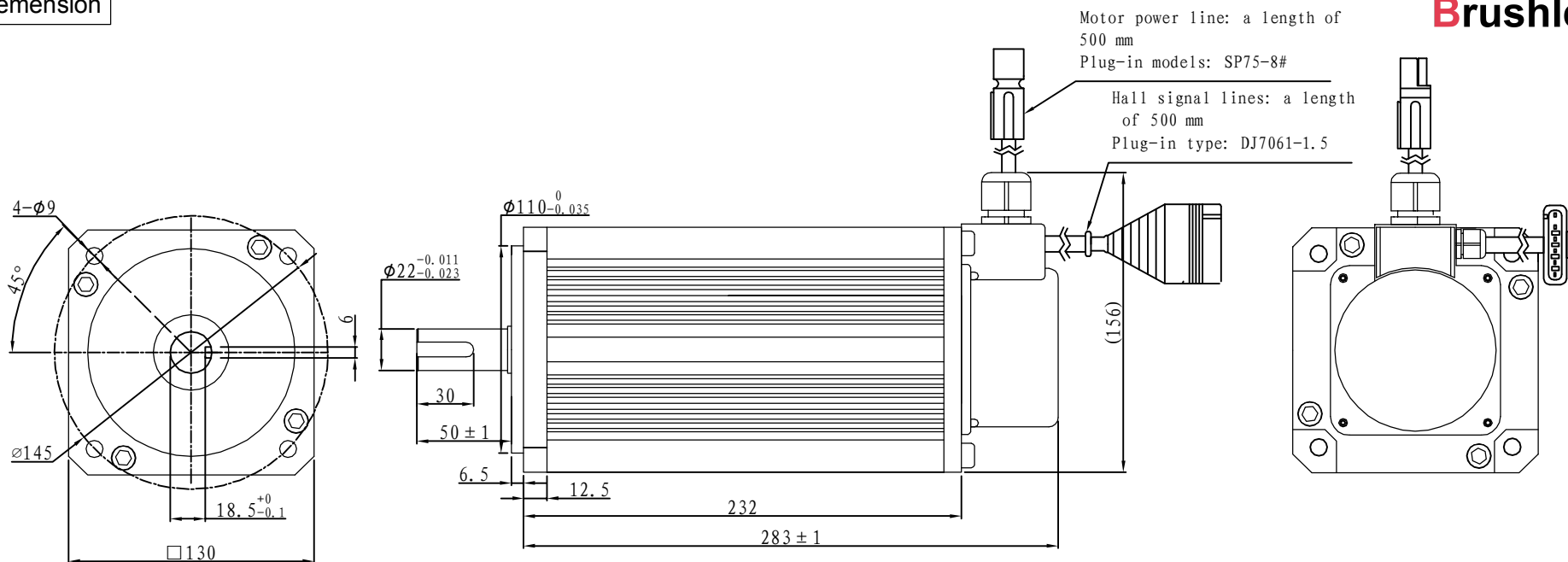

## Motor to Hall Relationship

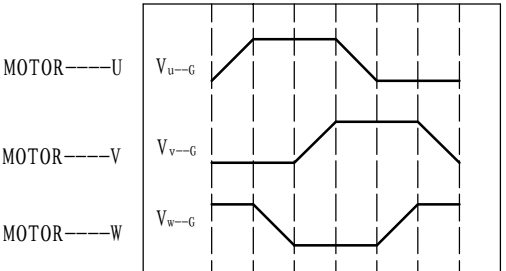
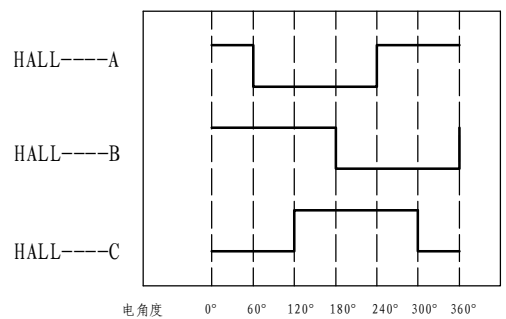

PHASE TO GROUND VOLTAGE  
 ROTATION CW FROM THE FLANGE

## Line Define

Power Wire	
Red	Motor U
Yellow	Motor V
Blue	Motor W

## Feedback Wire

Hall line colour	Hall signal definition	Plug serial number
Orange and black	5V	1
Orange	0V	2
Yellow	Hall A	4
Blue	Hall B	5
Green	Hall C	6

## Tecnichal Data

Type	130WD-M15030-72V
Power (KW)	4.7
Rated voltage (V)	72
Rated current (A)	77
Rated speed (rpm)	3000
Rated torque (NM)	15
Rotor inertia (Kgcm <sup>2</sup> )	32.4
Protection rank	IP65
Insulation rank	F
Appropriate environment	Temperature: 0 ~ 50°C Humidity: < 90% (No dewdrop)
Motor weight (KG)	12

# Demension

# Brushless

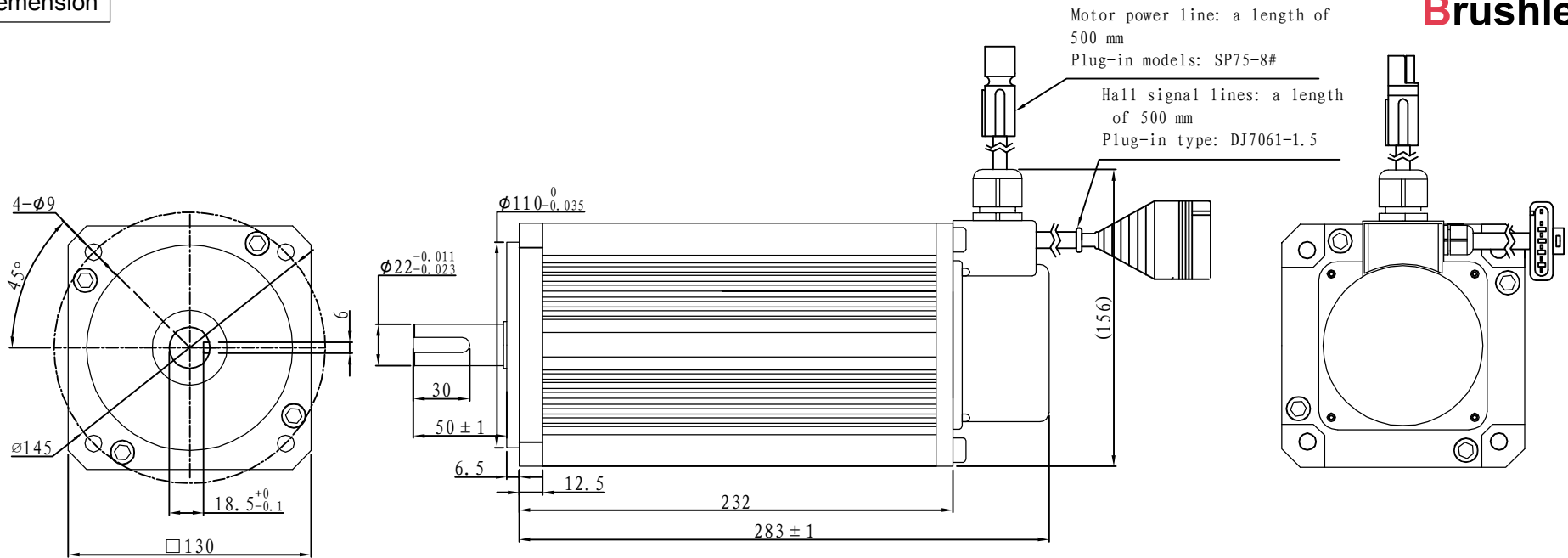

## Motor to Hall Relationship

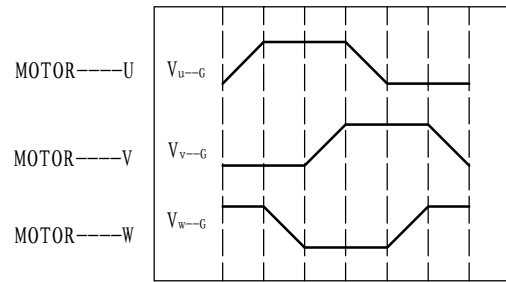
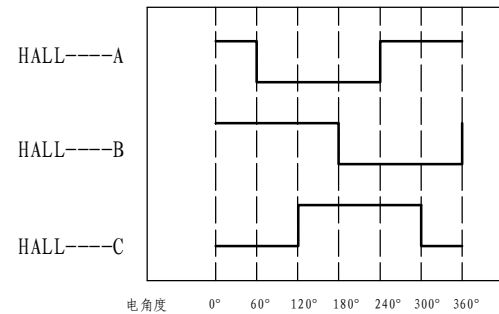

PHASE TO GROUND VOLTAGE  
 ROTATION CW FROM THE FLANGE

## Line Define

### Power Wire

Red	Motor U
Yellow	Motor V
Blue	Motor W

### Feedback Wire

Hall line colour	Hall signal definition	Plug serial number
Orange and black	5V	1
Orange	0V	2
Yellow	Hall A	4
Blue	Hall B	5
Green	Hall C	6

## Tecnichal Data

Type	130WD-M15030-96V
Power (KW)	4.7
Rated voltage (V)	96
Rated current (A)	57.7
Rated speed (rpm)	3000
Rated torque (NM)	15
Rotor inertia (Kgcm <sup>2</sup> )	32.4
Protection rank	IP65
Insulation rank	F
Appropriate environment	Temperature: 0~50℃ Humidity: <90% (No dewdrop)
Motor weight (KG)	12