

Demension

Brushless

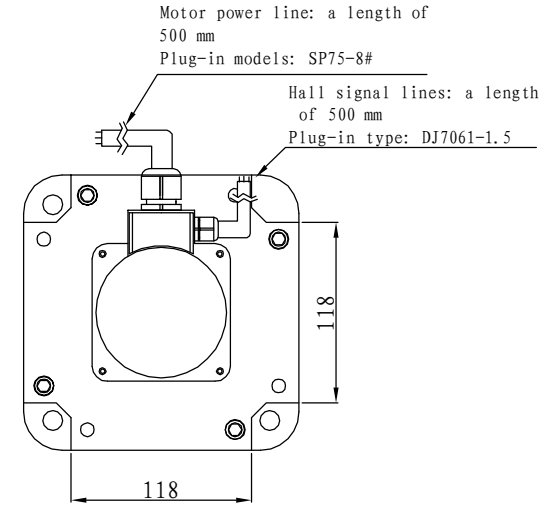

Motor to Hall Relationship

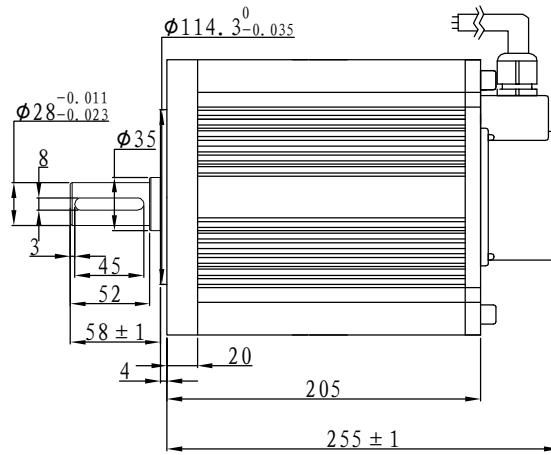
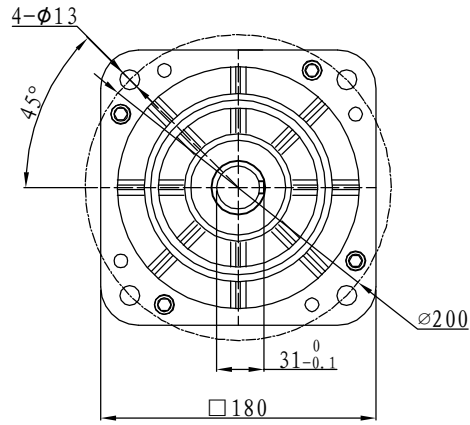
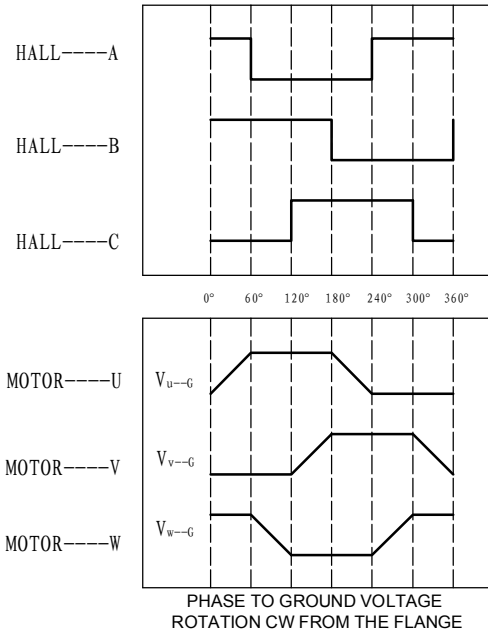

Line Define

Power Wire

| | |
|--------|---------|
| Red | Motor U |
| Yellow | Motor V |
| Blue | Motor W |

Feedback Wire

| Hall line colour | Hall signal definition | Plug serial number |
|------------------|------------------------|--------------------|
| Orange and black | 5V | 1 |
| Orange | 0V | 2 |
| Yellow | Hall A | 4 |
| Blue | Hall B | 5 |
| Green | Hall C | 6 |

Tecnichal Data

| | |
|------------------------------------|--|
| Type | 180WD-M16010-48V |
| Power (KW) | 1.7 |
| Rated voltage (V) | 48 |
| Rated current (A) | 41 |
| Rated speed(rpm) | 1000 |
| Rated torque (NM) | 16 |
| Rotor inertia (Kgcm ²) | 55 |
| Protection rank | IP65 |
| Insulation rank | F |
| Appropriate environment | Temperature: 0 ~ 50°C Humidity: < 90% (No dewdrop) |
| Motor weight (KG) | 18.6 |

Demension

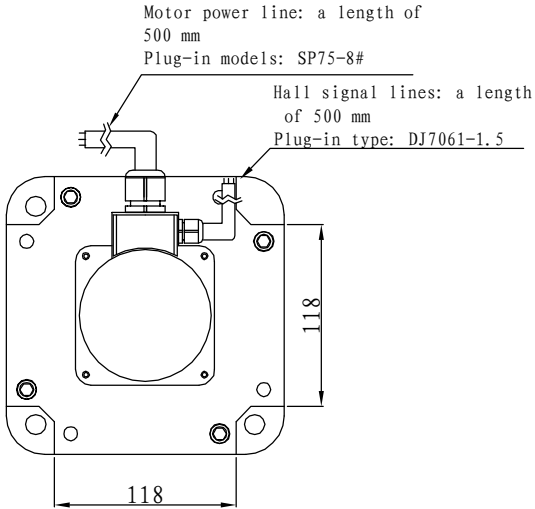
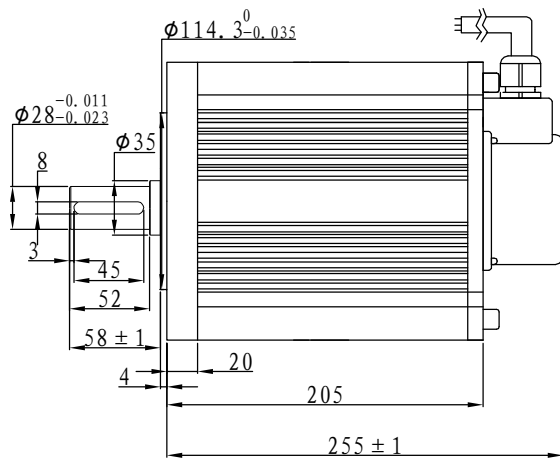
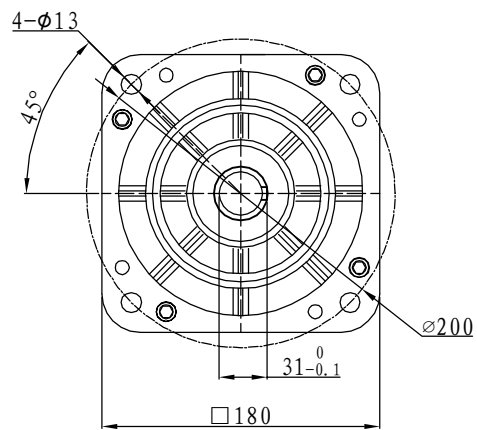

Motor to Hall Relationship

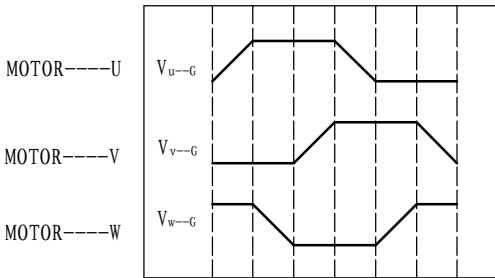
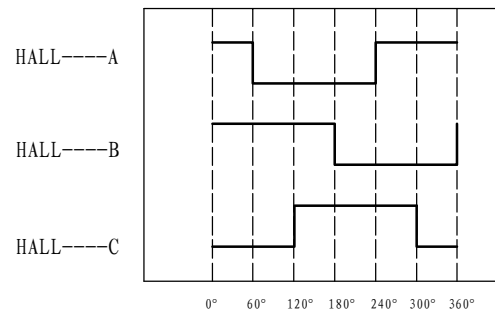

PHASE TO GROUND VOLTAGE
ROTATION CW FROM THE FLANGE

Line Define

Power Wire

| | |
|--------|---------|
| Red | Motor U |
| Yellow | Motor V |
| Blue | Motor W |

Feedback Wire

| Hall line colour | Hall signal definition | Plug serial number |
|------------------|------------------------|--------------------|
| Orange and black | 5V | 1 |
| Orange | 0V | 2 |
| Yellow | Hall A | 4 |
| Blue | Hall B | 5 |
| Green | Hall C | 6 |

Tecnichal Data

| | |
|------------------------------------|--|
| Type | 180WD-M16010-72V |
| Power (KW) | 1.7 |
| Rated voltage (V) | 72 |
| Rated current (A) | 27 |
| Rated speed (rpm) | 1000 |
| Rated torque (NM) | 16 |
| Rotor inertia (Kgcm ²) | 55 |
| Protection rank | IP65 |
| Insulation rank | F |
| Appropriate environment | Temperature: 0~50℃ Humidity: <90% (No dewdrop) |
| Motor weight (KG) | 18.6 |

Demension

Brushless

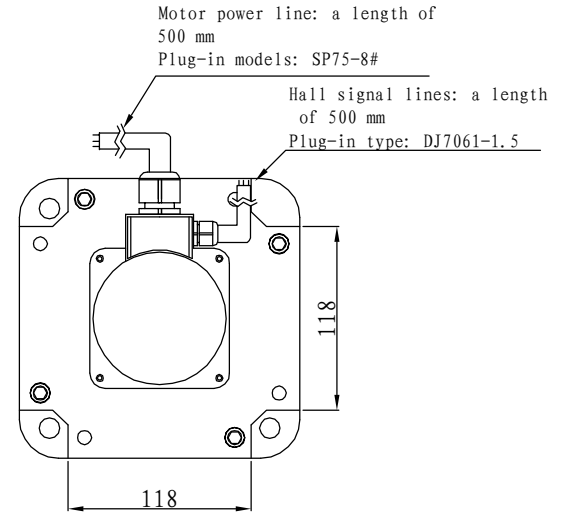
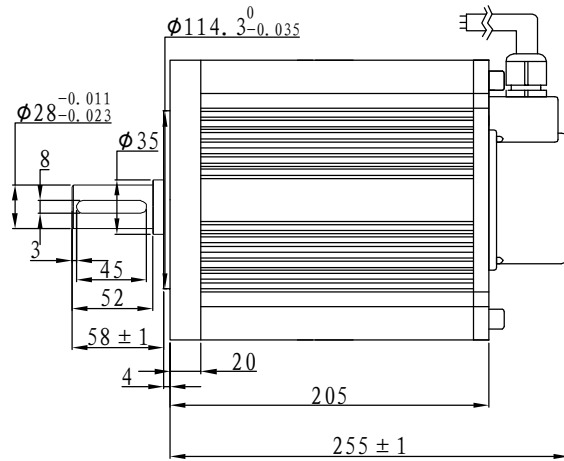
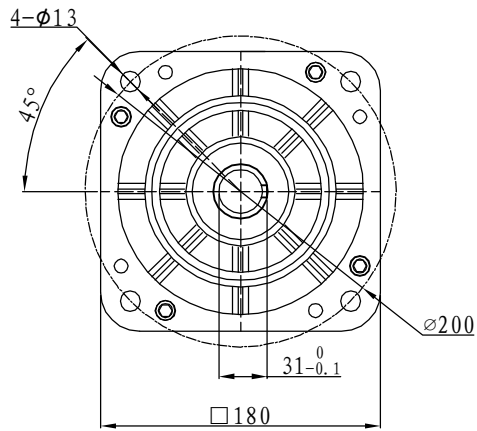

Motor to Hall Relationship

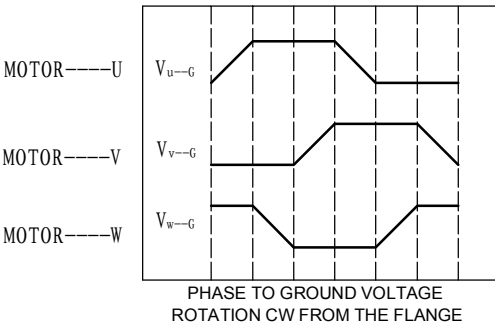
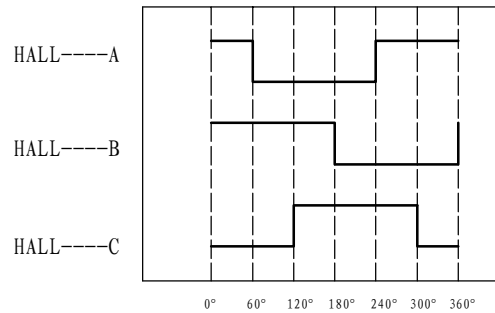

Line Define

Power Wire

| | |
|--------|---------|
| Red | Motor U |
| Yellow | Motor V |
| Blue | Motor W |

Feedback Wire

| Hall line colour | Hall signal definition | Plug serial number |
|------------------|------------------------|--------------------|
| Orange and black | 5V | 1 |
| Orange | 0V | 2 |
| Yellow | Hall A | 4 |
| Blue | Hall B | 5 |
| Green | Hall C | 6 |

Tecnichal Data

| | |
|------------------------------------|--|
| Type | 180WD-M16010-96V |
| Power (KW) | 1.7 |
| Rated voltage (V) | 96 |
| Rated current (A) | 21 |
| Rated speed (rpm) | 1000 |
| Rated torque (NM) | 16 |
| Rotor inertia (Kgcm ²) | 55 |
| Protection rank | IP65 |
| Insulation rank | F |
| Appropriate environment | Temperature: 0~50℃ Humidity: <90% (No dewdrop) |
| Motor weight (KG) | 18.6 |