

# Demension

# Brushless

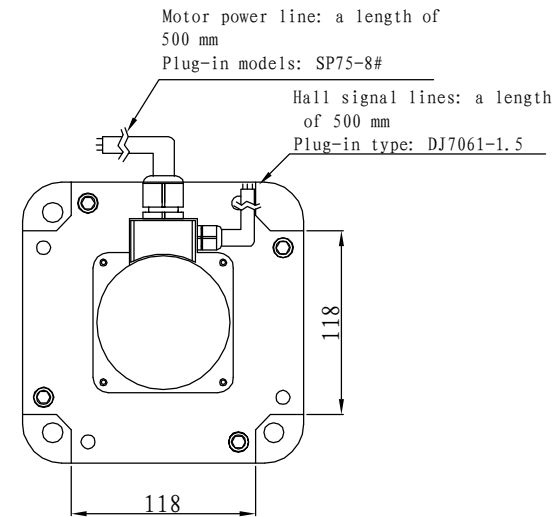

## Motor to Hall Relationship

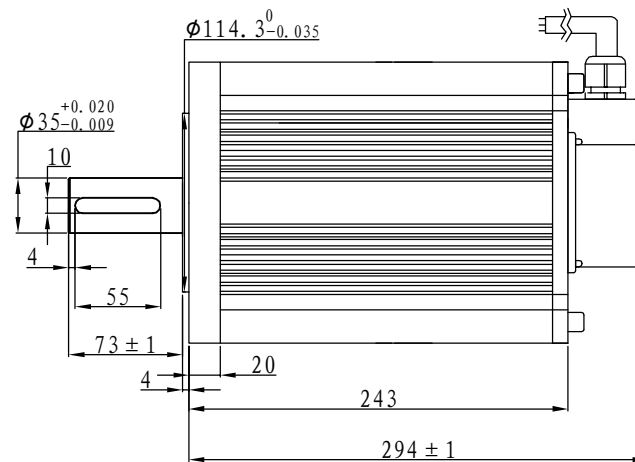
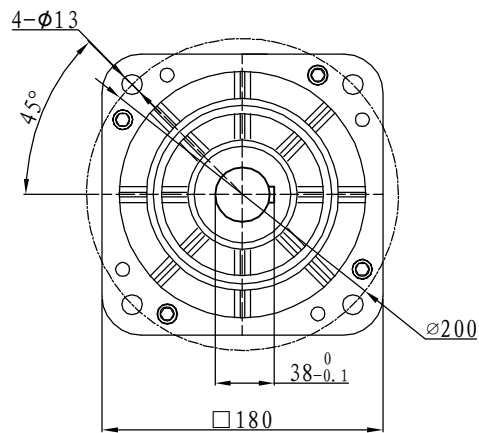
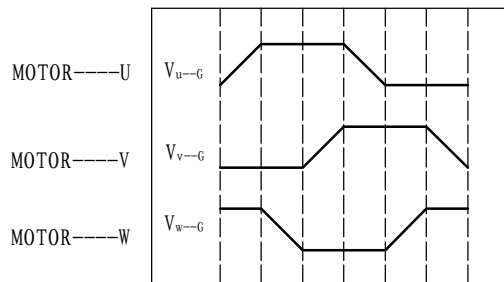
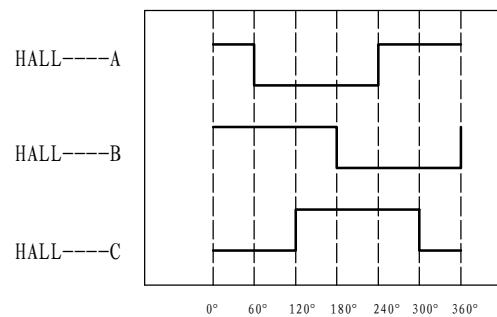

PHASE TO GROUND VOLTAGE  
ROTATION CW FROM THE FLANGE

## Line Define

### Power Wire

Red	Motor U
Yellow	Motor V
Blue	Motor W

### Feedback Wire

Hall line colour	Hall signal definition	Plug serial number
Orange and black	5V	1
Orange	0V	2
Yellow	Hall A	4
Blue	Hall B	5
Green	Hall C	6

## Tecnichal Data

Type	180WD-M25010-48V
Power (KW)	2.6
Rated voltage (V)	48
Rated current (A)	64
Rated speed (rpm)	1000
Rated torque (NM)	25
Rotor inertia (Kgcm <sup>2</sup> )	55
Protection rank	IP65
Insulation rank	F
Appropriate environment	Temperature: 0~50°C Humidity: <90% (No dewdrop)
Motor weight (KG)	26

## Demension

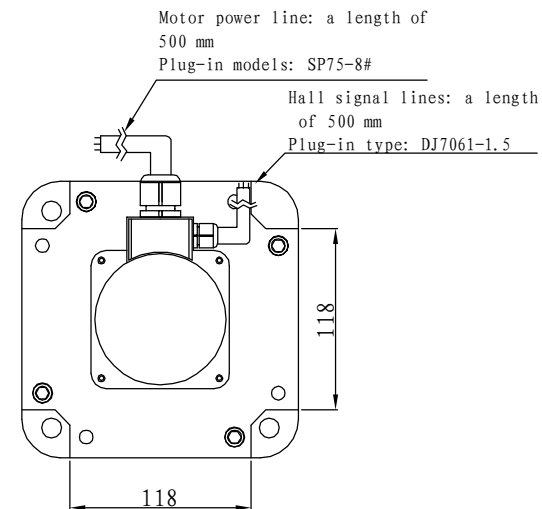
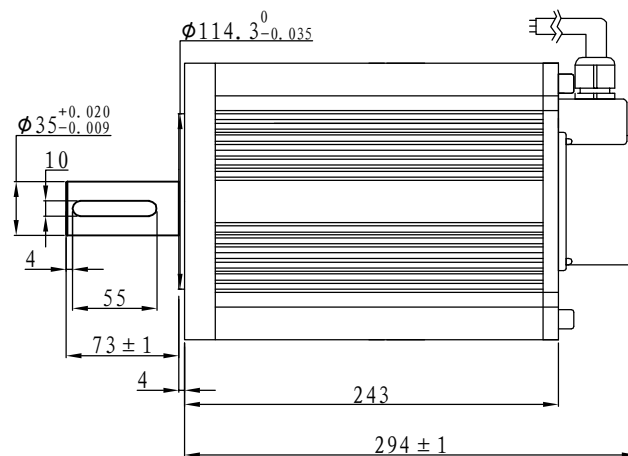
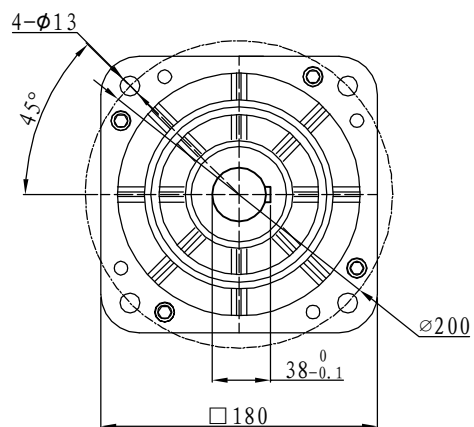

## Motor to Hall Relationship

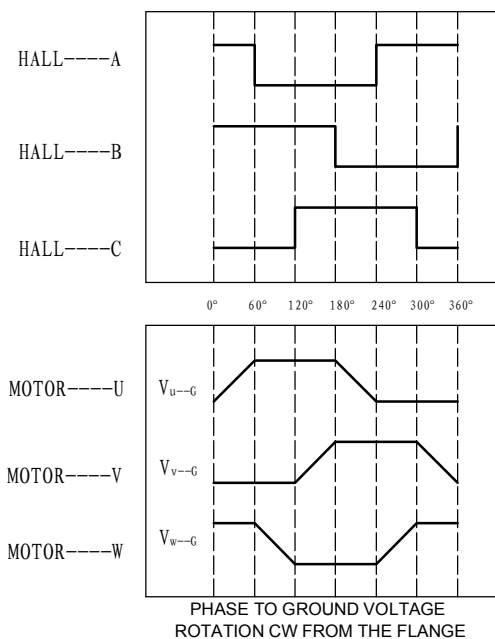

## Line Define

### Power Wire

Red	Motor U
Yellow	Motor V
Blue	Motor W

### Feedback Wire

Hall line colour	Hall signal definition	Plug serial number
Orange and black	5V	1
Orange	0V	2
Yellow	Hall A	4
Blue	Hall B	5
Green	Hall C	6

## Tecnichal Data

Type	180WD-M25010-72V
Power (KW)	2.6
Rated voltage (V)	72
Rated current (A)	4.3
Rated speed (rpm)	1000
Rated torque (NM)	2.5
Rotor inertia (Kgcm <sup>2</sup> )	55
Protection rank	IP65
Insulation rank	F
Appropriate environment	Temperature: 0 ~ 50°C Humidity: <90% (No dewdrop)
Motor weight (KG)	2.6

# Demension

# Brushless

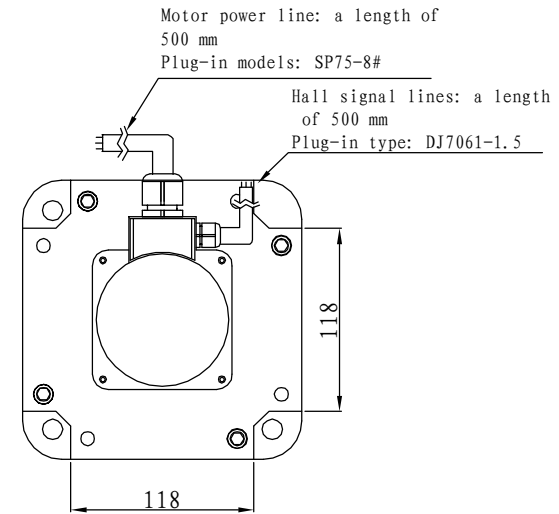
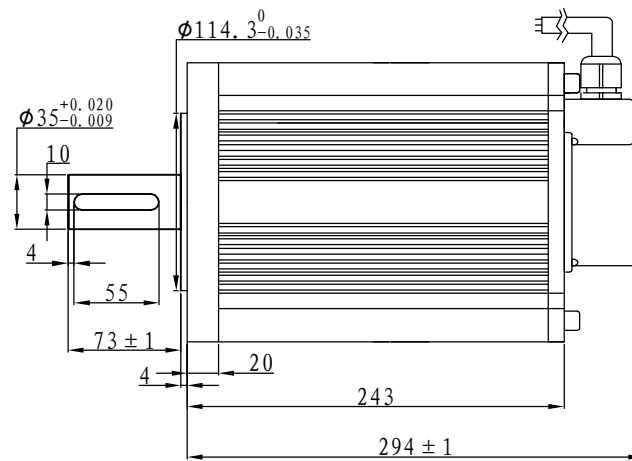
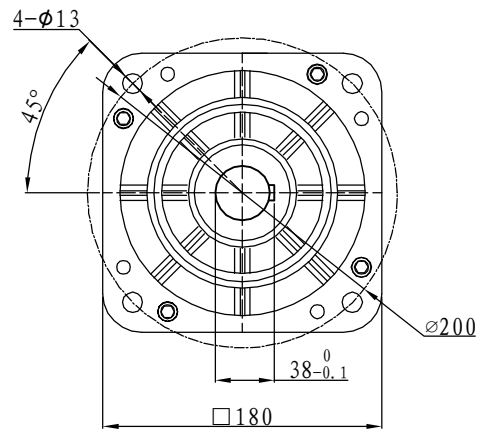

## Motor to Hall Relationship

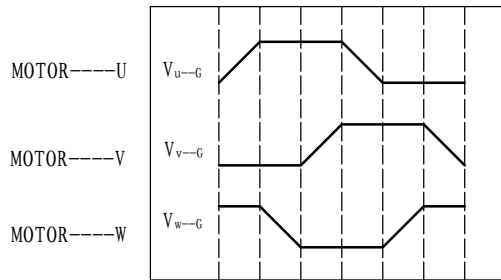
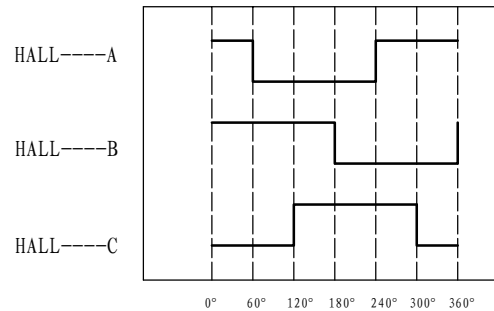

PHASE TO GROUND VOLTAGE  
ROTATION CW FROM THE FLANGE

## Line Define

### Power Wire

Red	Motor U
Yellow	Motor V
Blue	Motor W

### Feedback Wire

Hall line colour	Hall signal definition	Plug serial number
Orange and black	5V	1
Orange	0V	2
Yellow	Hall A	4
Blue	Hall B	5
Green	Hall C	6

## Tecnichal Data

Type	180WD-M25010-96V
Power (KW)	2.6
Rated voltage (V)	96
Rated current (A)	32
Rated speed (rpm)	1000
Rated torque (NM)	25
Rotor inertia (Kgcm <sup>2</sup> )	55
Protection rank	IP65
Insulation rank	F
Appropriate environment	Temperature: 0~50°C Humidity: <90% (No dewdrop)
Motor weight (KG)	26