

Demension

Brushless

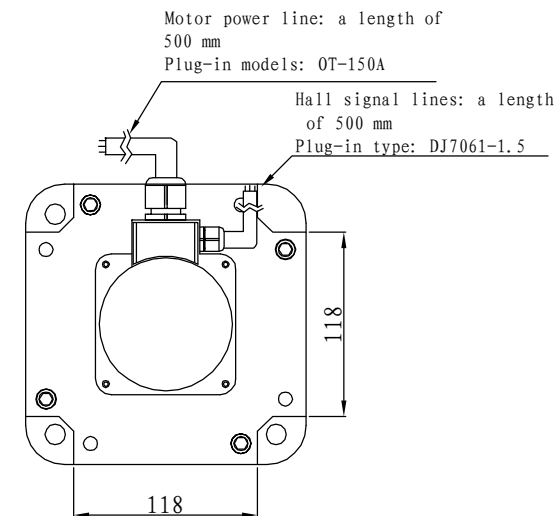

Motor to Hall Relationship

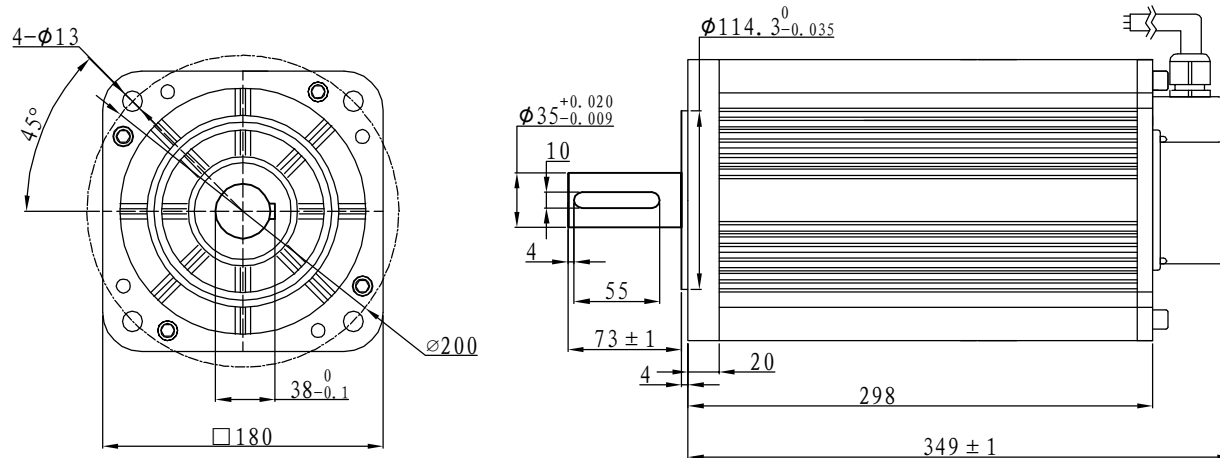
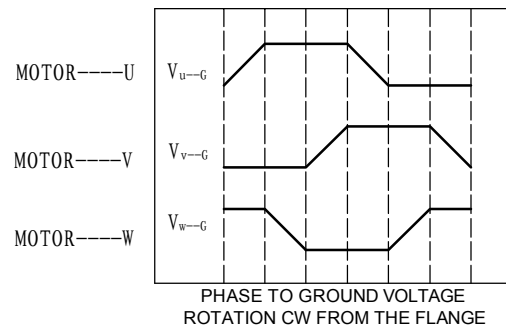
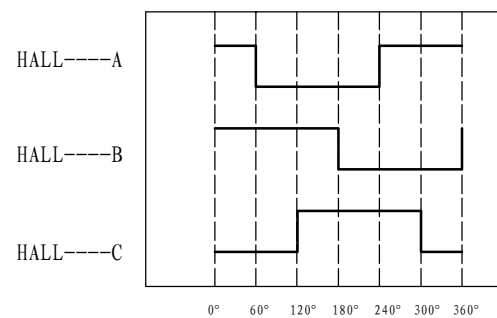

Line Define

Power Wire

Red	Motor U
Yellow	Motor V
Blue	Motor W

Feedback Wire

Hall line colour	Hall signal definition	Plug serial number
Orange and black	5V	1
Orange	0V	2
Yellow	Hall A	4
Blue	Hall B	5
Green	Hall C	6

Tecnichal Data

Type	180WD-M36020-48V
Power (KW)	7.5
Rated voltage (V)	48
Rated current (A)	185
Rated speed (rpm)	2000
Rated torque (NM)	36
Rotor inertia (Kgcm ²)	148
Protection rank	IP65
Insulation rank	F
Appropriate environment	Temperature: 0~50℃ Humidity: <90% (No dewdrop)
Motor weight (KG)	30

Demension

Brushless

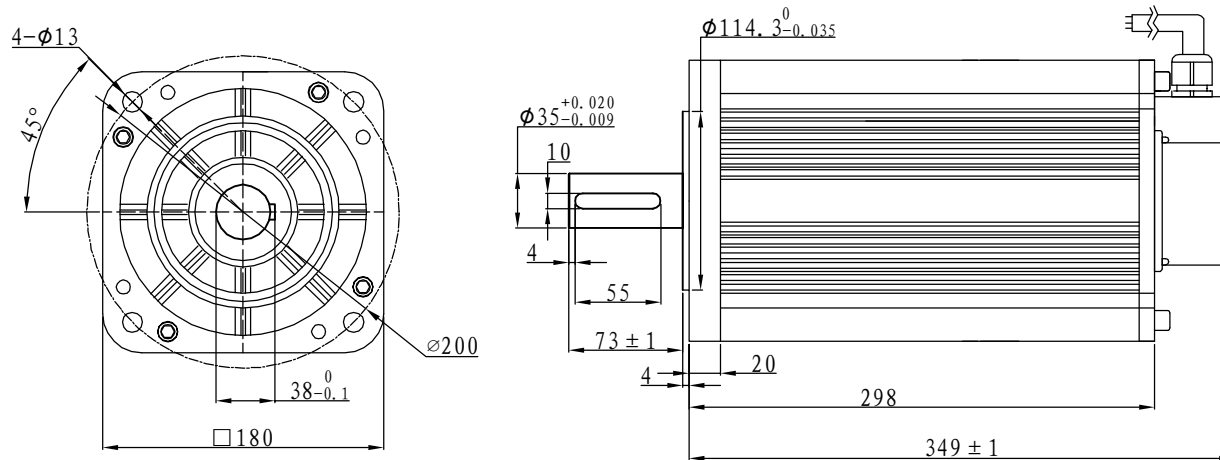

Motor power line: a length of 500 mm
 Plug-in models: OT-150A

Hall signal lines: a length of 500 mm
 Plug-in type: DJ7061-1.5

Motor to Hall Relationship

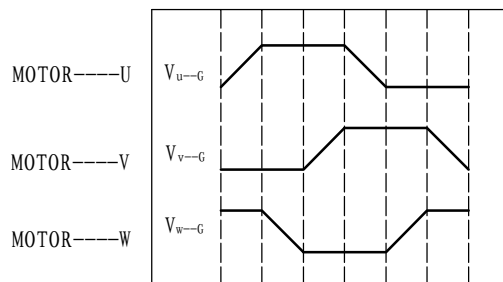
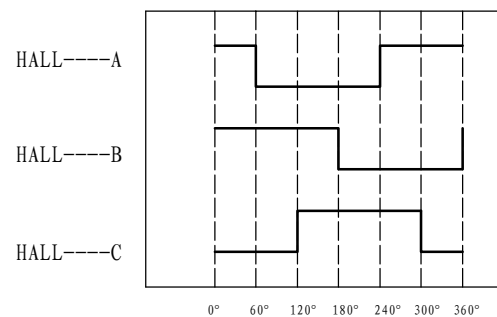

PHASE TO GROUND VOLTAGE
 ROTATION CW FROM THE FLANGE

Line Define

Power Wire

Red	Motor U
Yellow	Motor V
Blue	Motor W

Feedback Wire

Hall line colour	Hall signal definition	Plug serial number
Orange and black	5V	1
Orange	0V	2
Yellow	Hall A	4
Blue	Hall B	5
Green	Hall C	6

Tecnichal Data

Type	180WD-M36020-72V
Power (KW)	7.5
Rated voltage (V)	72
Rated current (A)	123
Rated speed (rpm)	2000
Rated torque (NM)	36
Rotor inertia (Kgc ^m 2)	148
Protection rank	IP65
Insulation rank	F
Appropriate environment	Temperature: 0~50°C Humidity: <90% (No dewdrop)
Motor weight (KG)	30

Demension

Brushless

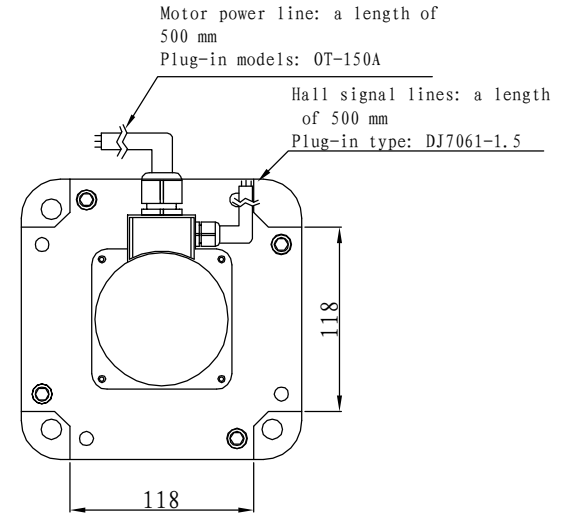
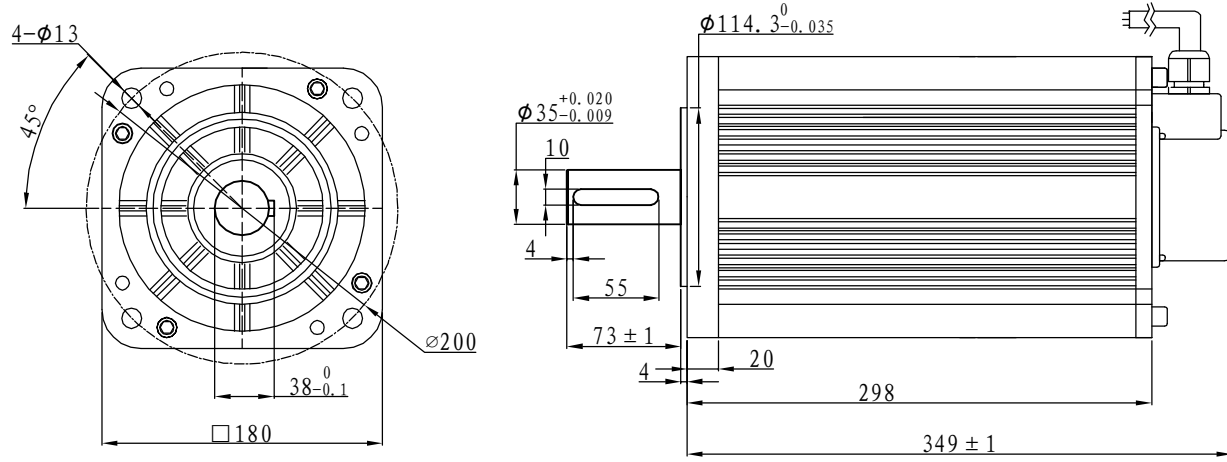

Motor to Hall Relationship

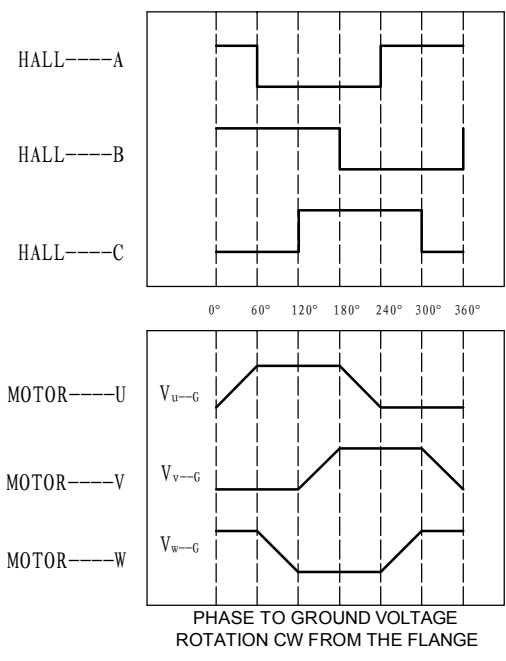

Line Define

Power Wire	
Red	Motor U
Yellow	Motor V
Blue	Motor W

Feedback Wire		
Hall line colour	Hall signal definition	Plug serial number
Orange and black	5V	1
Orange	0V	2
Yellow	Hall A	4
Blue	Hall B	5
Green	Hall C	6

Tecnichal Data

Type	180WD-M36020-96V
Power (KW)	7.5
Rated voltage (V)	96
Rated current (A)	92
Rated speed (rpm)	2000
Rated torque (NM)	36
Rotor inertia (Kgc ^{m2})	148
Protection rank	IP65
Insulation rank	F
Appropriate environment	Temperature: 0~50°C Humidity: <90% (No dewdrop)
Motor weight (KG)	30