

Demension

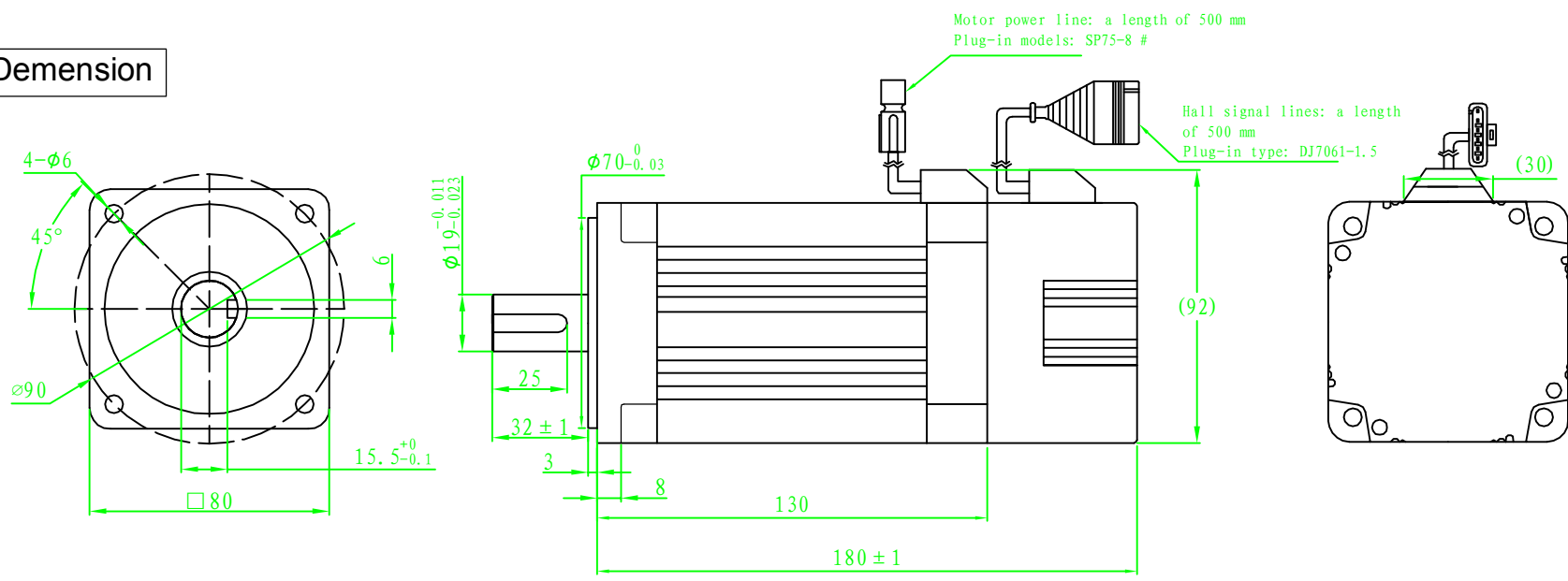

Motor to Hall Relationship

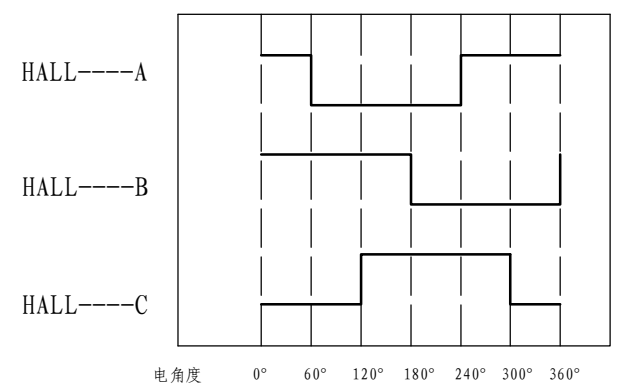

Line Define

Power Wire

Red	Motor U
Yellow	Motor V
Blue	Motor W

Feedback Wire

Hall line colour	Hall signal definition	Plug serial number
Orange and black	5V	1
Orange	0V	2
Yellow	Hall A	3
Blue	Hall B	4
Green	Hall C	5

Tecnichal Data

Type	80WD-M02430-24V
Power (KW)	0.75
Rated voltage (V)	24
Rated current (A)	39.27
Rated speed (rpm)	3000
Rated torque (NM)	2.4
Rotor inertia (Kgcm2)	0.8
Protection rank	IP54
Insulation rank	F
Appropriate environment	Temperature: 0 ~ 50°C Humidity: <90% (No dewdrop)
Motor weight (KG)	3

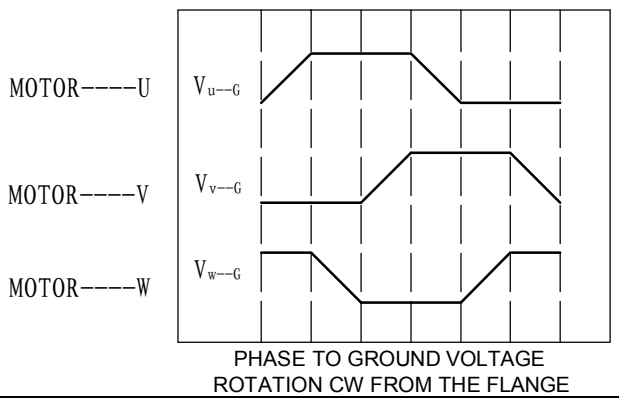

Brushless

Demension

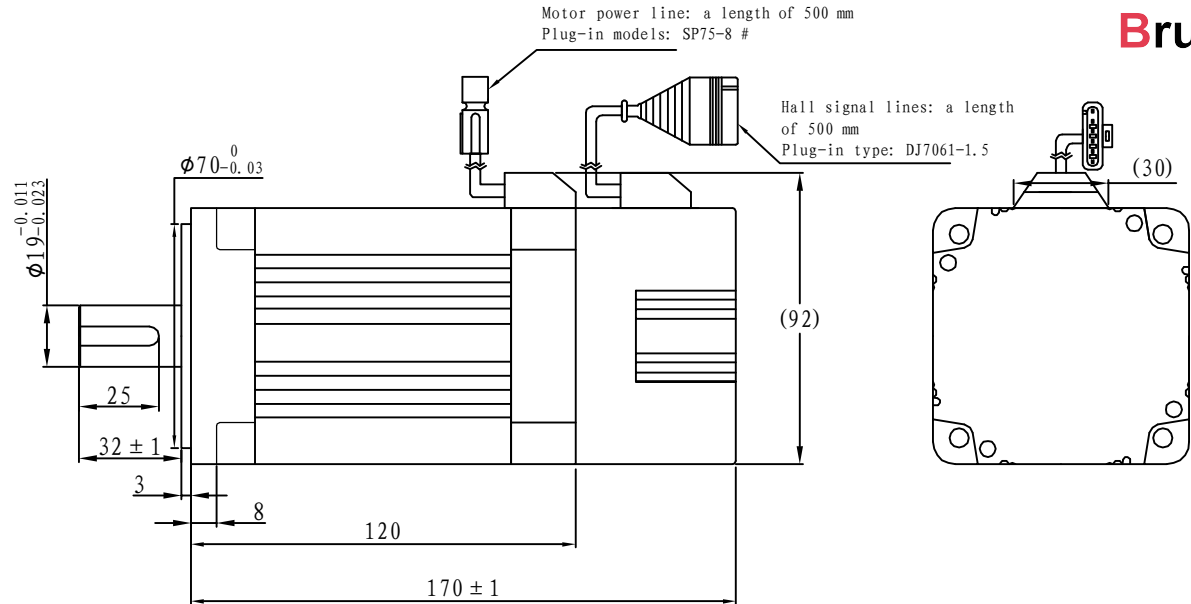
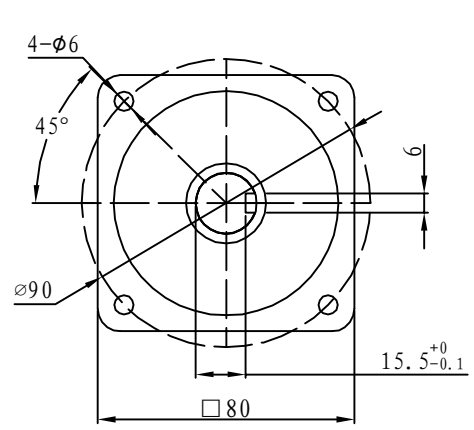

Motor to Hall Relationship

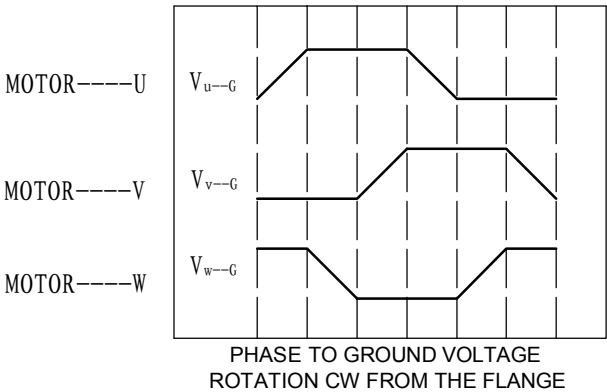
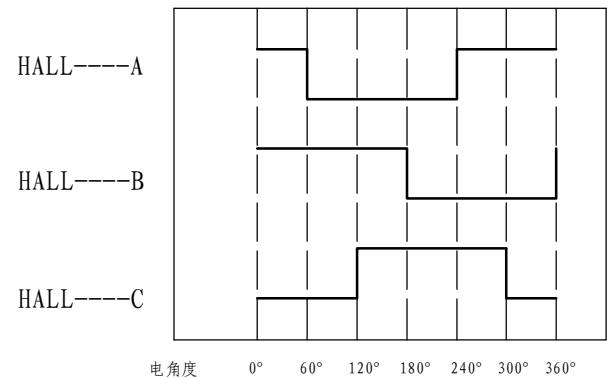

Line Define

Power Wire

Red	Motor U
Yellow	Motor V
Blue	Motor W

Feedback Wire

Hall line colour	Hall signal definition	Plug serial number
Orange and black	5V	1
Orange	0V	2
Yellow	Hall A	3
Blue	Hall B	4
Green	Hall C	5

Tecnichal Data

Type	80WD-M02430-48V
Power (KW)	0.75
Rated voltage (V)	48
Rated current (A)	19.5
Rated speed (rpm)	3000
Rated torque (NM)	2.4
Rotor inertia (Kgcm ²)	0.8
Protection rank	IP54
Insulation rank	F
Appropriate environment	Temperature: 0 ~ 50℃ Humidity: <90% (No dewdrop)
Motor weight (KG)	3

Demension

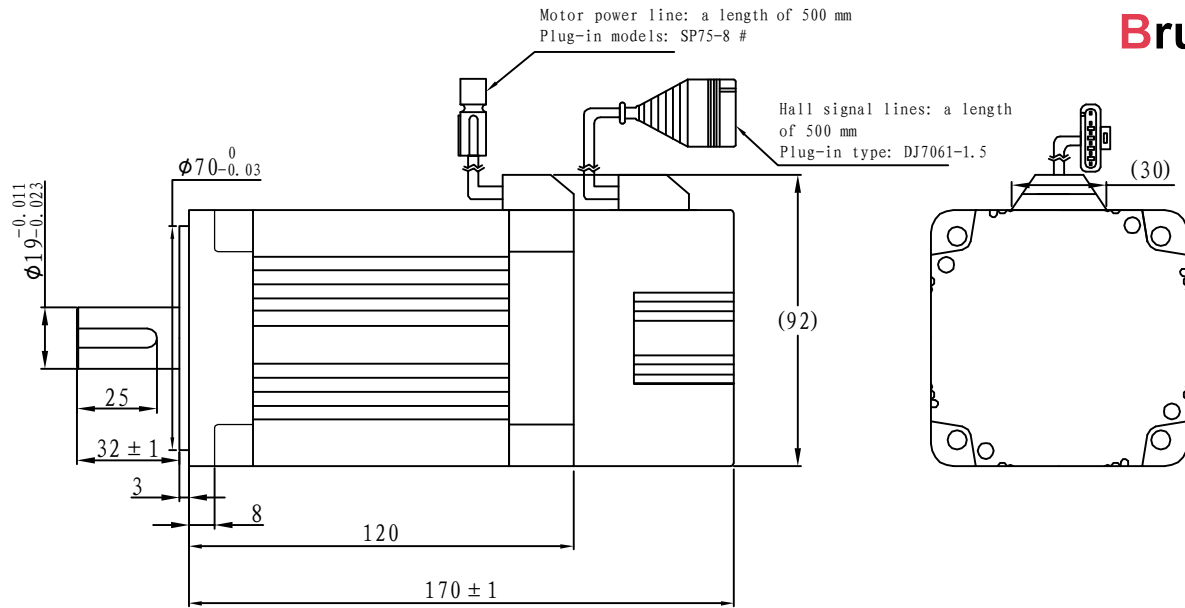
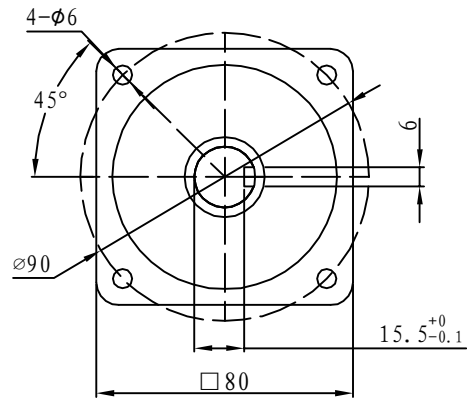

Motor to Hall Relationship

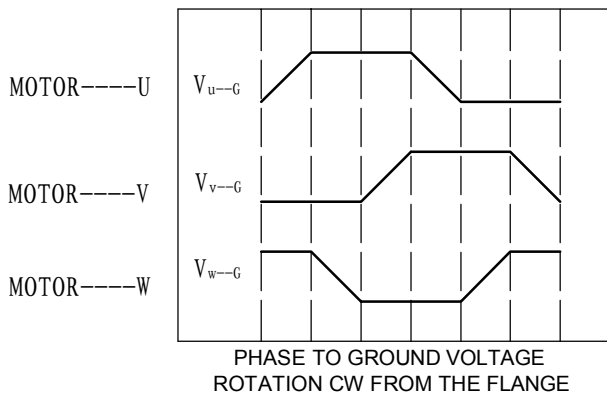
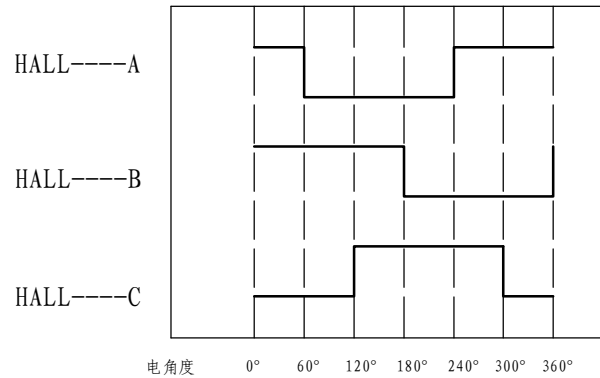

Line Define

Power Wire

Red	Motor U
Yellow	Motor V
Blue	Motor W

Feedback Wire

Hall line colour	Hall signal definition	Plug serial number
Orange and black	5V	1
Orange	0V	2
Yellow	Hall A	3
Blue	Hall B	4
Green	Hall C	5

Tecnichal Data

Type	80WD-M02430-72V
Power (KW)	0.75
Rated voltage (V)	72
Rated current (A)	13.09
Rated speed (rpm)	3000
Rated torque (NM)	2.4
Rotor inertia (Kgcm ²)	0.8
Protection rank	IP54
Insulation rank	F
Appropriate environment	Temperature: 0 ~ 50°C Humidity: <90% (No dewdrop)
Motor weight (KG)	3

Brushless

Demension

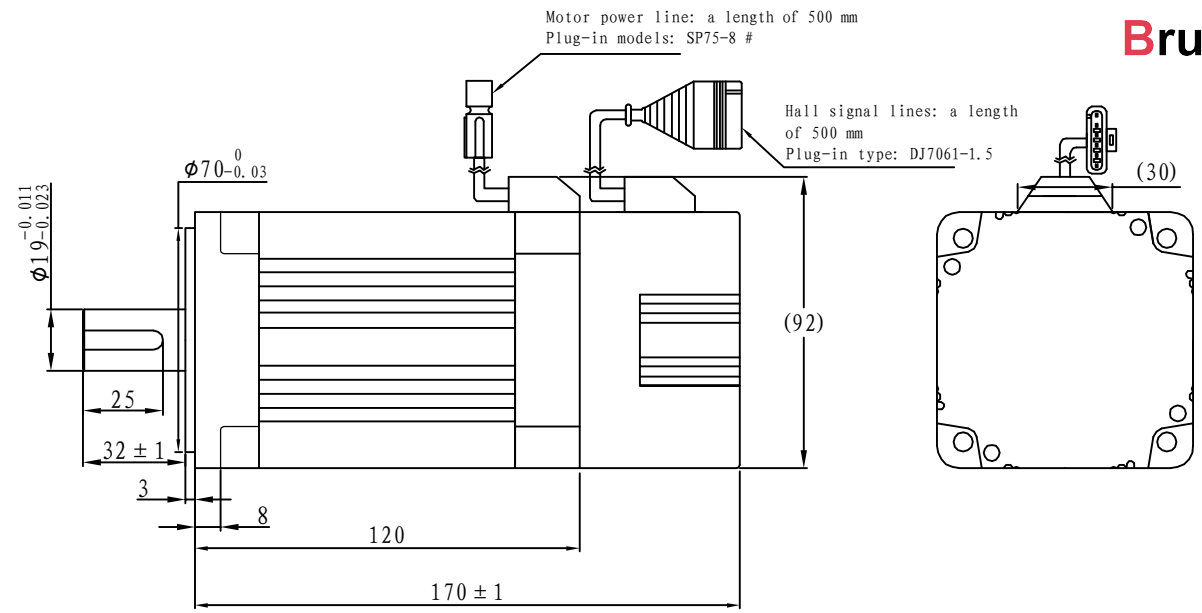
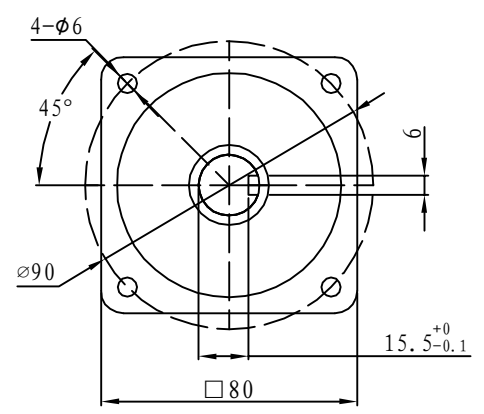

Motor to Hall Relationship

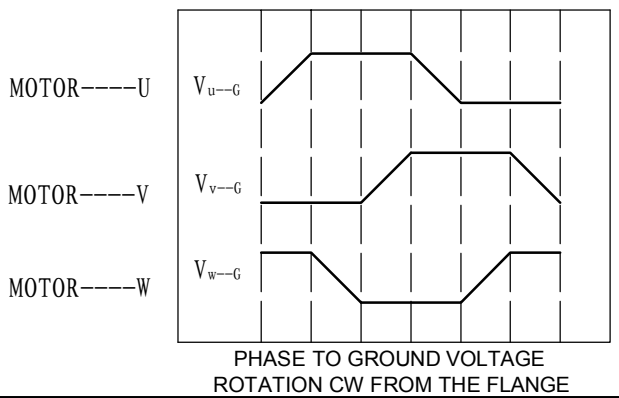
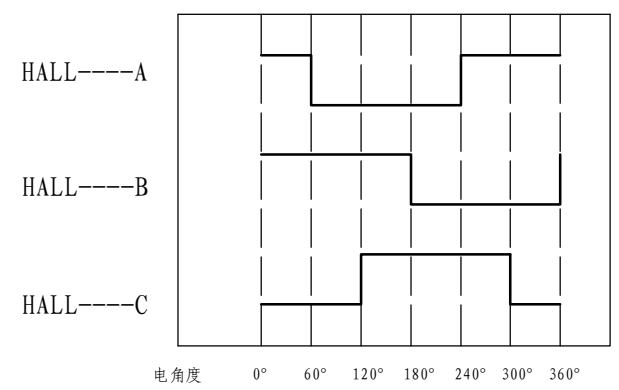

Line Define

Power Wire

Red	Motor U
Yellow	Motor V
Blue	Motor W

Feedback Wire

Hall line colour	Hall signal definition	Plug serial number
Orange and black	5V	1
Orange	0V	2
Yellow	Hall A	3
Blue	Hall B	4
Green	Hall C	5

Tecnichal Data

Type	80WD-M02430-96V
Power (KW)	0.75
Rated voltage (V)	96
Rated current (A)	9.82
Rated speed (rpm)	3000
Rated torque (NM)	2.4
Rotor inertia (Kgcm ²)	0.8
Protection rank	IP54
Insulation rank	F
Appropriate environment	Temperature: 0 ~ 50°C Humidity: <90% (No dewdrop)
Motor weight (KG)	3